

Amplified Piezoelectric Accelerometer

Model PA



HIGH SENSITIVITY

CASE ISOLATED

RUGGED, HIGH IMPACT

The SENSOTEC Model PA amplified piezoelectric accelerometers are designed to be used in test/measurement and industrial environments; including laboratory testing, modal studies and vibration testing for engine, turbine monitoring, and mining engineering. The low output impedance combined with the ability to drive high load capacitance allows long runs of low cost cable without degradation of data. The Model PA features high natural frequency, a wide frequency range, and a flat sensitivity vs. temperature response over the temperature range. Since the unit has very low internal damping, there is very low phase shift over the operating frequency range.

This seismic element is mechanically isolated from the mounting base, resulting in a low strain sensitivity. All materials are non-magnetic resulting in very low magnetic field susceptibility. These features, together with a sealed enclosure, assure, accurate and reliable data.

The 1/4-28 UNF mounting hole is provided for easy installation. The Model PA accelerometer is well suited for rough industrial environments where a small size and a rugged electrical connector is needed. A six pin connector with a heavy gauge wall is welded to the top of the accelerometer. Any 4 conductor cable may be used.

PERFORMANCE

Capacities	±5 to ±1000g
Useable Frequency Range	3 to 5,000 Hz
Full Scale Output	±5 V
Mounted Natural Frequency	30kHz
Transverse Sensitivity	5% of F.S.

ENVIRONMENTAL

Shock Limits	3000g
Vibration Limits	2000g
Operating Temperature Range	-40° F to 200° F

ELECTRICAL

Input Power	±13.5 to ±16.5 Vdc
Output Impedance	100 ohms
Connector	PTIH-10-6P

MECHANICAL

Weight	3 oz.
Case Material	316 SS
Sealing	Welded

Order Code: AG714

Dimensions

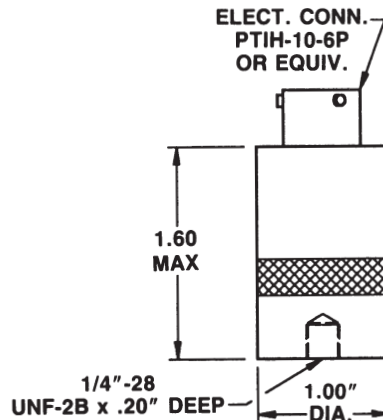

Wiring Code:

- A + 13.5 to 16.5 VDC
- B — output/supply common
- C — 13.5 to —16.5 VDC
- D + output (±5 VDC)
- E N/A
- F N/A

Sensitivity Table

Range	Sensitivity
5g	1,000mV/g
10g	500mV/g
50g	100mV/g
100g	50mV/g
500g	10mV/g
1,000g	5mV/g

Accessories: Mating connector AA111; Cable assembly AA165. See Appendix.

SUNSTAR 商斯达实业集团是集研发、生产、工程、销售、代理经销、技术咨询、信息服务等为一体的高科技企业，是专业高科技电子产品生产厂家，是具有 10 多年历史的专业电子元器件供应商，是中国最早和最大的仓储式连锁规模经营大型综合电子零部件代理分销商之一，是一家专业代理和分销世界各大品牌 IC 芯片和电子元器件的连锁经营综合性国际公司，专业经营进口、国产名厂名牌电子元件，型号、种类齐全。在香港、北京、深圳、上海、西安、成都等全国主要电子市场设有直属分公司和产品展示展销窗口门市部专卖店及代理分销商，已在全国范围内建成强大统一的供货和代理分销网络。我们专业代理经销、开发生产电子元器件、集成电路、传感器、微波光电元器件、工控机/DOC/DOM 电子盘、专用电路、单片机开发、MCU/DSP/ARM/FPGA 软件硬件、二极管、三极管、模块等，是您可靠的一站式现货配套供应商、方案提供商、部件功能模块开发配套商。商斯达实业公司拥有庞大的资料库，有数位毕业于著名高校——有中国电子工业摇篮之称的西安电子科技大学（西军电）并长期从事国防尖端科技研究的高级工程师为您精挑细选、量身订做各种高科技电子元器件，并解决各种技术问题。

更多产品请看本公司产品专用销售网站：

商斯达中国传感器科技信息网：<http://www.sensor-ic.com/>

商斯达工控安防网：<http://www.pc-ps.net/>

商斯达电子元器件网：<http://www.sunstare.com/>

商斯达微波光电产品网：[HTTP://www.rfoe.net/](http://www.rfoe.net/)

商斯达消费电子产品网：<http://www.icasic.com/>

商斯达实业科技产品网：<http://www.sunstars.cn/>

传感器销售热线：

地址：深圳市福田区福华路福庆街鸿图大厦 1602 室

电话：0755-83370250 83376489 83376549 83607652 83370251 82500323

传真：0755-83376182 (0) 13902971329 MSN: SUNS8888@hotmail.com

邮编：518033 E-mail:szss20@163.com QQ: 195847376

深圳赛格展销部：深圳华强北路赛格电子市场 2583 号 电话：0755-83665529 25059422

技术支持：0755-83394033 13501568376

欢迎索取免费详细资料、设计指南和光盘；产品凡多，未能尽录，欢迎来电查询。

北京分公司：北京海淀区知春路 132 号中发电子大厦 3097 号

TEL: 010-81159046 82615020 13501189838 FAX: 010-62543996

上海分公司：上海市北京东路 668 号上海赛格电子市场 2B35 号

TEL: 021-28311762 56703037 13701955389 FAX: 021-56703037

西安分公司：西安高新开发区 20 所(中国电子科技集团导航技术研究所)

西安劳动南路 88 号电子商城二楼 D23 号

TEL: 029-81022619 13072977981 FAX:029-88789382