

OEM Flow sensor for liquid media type 235

Flow range

1.8 ... 240 l/min

Nominal diameters

DN 10 / 32

Temperature measurement

-40 ... +125 °C

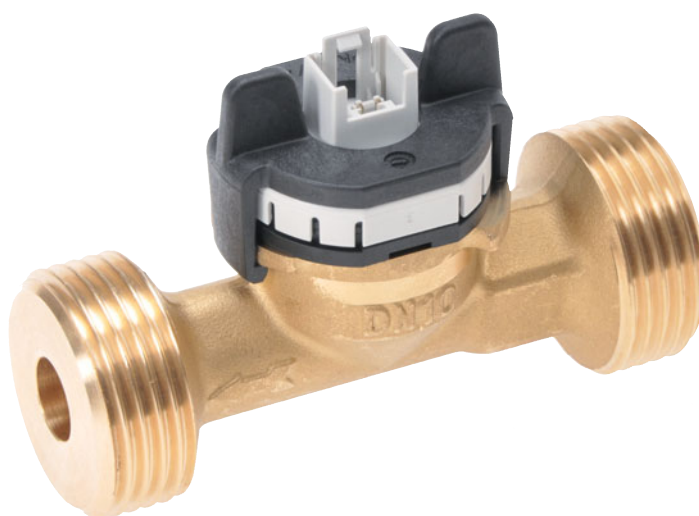

The type 235 is based on the type 200 but incorporates a brass housing. The flow sensor type 235 is based on the Kármán vortex trail. You can choose between various versions as integrated temperature measurement. With no moving parts the flow sensor is not sensitive to debris, has marginal pressure loss and high accuracy.

- Low cost product with high levels of accuracy
- Temperature non-sensitive measuring principle
- Excellent media resistance (measuring element not in contact with the media)
- Wide application temperature range
- Marginal loss of pressure
- Measuring element not sensitive to debris
- Direct temperature measurement in the medium with PT1000 or NTC

Technical Overview

Flow measurement

Measuring principle	Vortex		Piezoelectric sensor element
Measuring range			1.8 ... 240 l/min
Nominal diameters			DN 10 / 25
Accuracy at < 50% fs (water)			< 1% fs
Accuracy at > 50% fs (water)			< 2% measuring value
Response time	Immediately	Signal delay	< 100 ms
	Therefore suitable for spigot use.	Response time	< 5 ms

Temperature measurement

Measuring principle	Resistance		PT1000
			NTC
PT1000	Measuring range	-40 ... +125 °C	
	Accuracy	Class B DIN EN 60751	@ T = 0 °C ± 0.3 K
			@ T ≠ 0 °C ± 0.3 K ± 0.005 * T
	Measuring range	-40 ... +125 °C	
NTC	Accuracy	NTC 10 kOhm @ 25 °C β = 4050	@ T = +25 °C ± 0.7 K @ T < +25 °C ± 0.7 K ± 0.025 * T @ T > +25 °C ± 0.7 K ± 0.050 * T
Temperature influences	Self-heating at temperature sensor		1 K/mW
	Conduction resistance to connector		0.8 Ohm

Operating conditions

Medium	Suitable for heating circuit water with the usual additives Drinking water		Other medium on request
Temperature			Media < +125 °C Ambient -15 ... +85 °C Storage -30 ... +85 °C
Max pressure and medium temperature			(for lifetime) 12 bar at +40 °C (for lifetime) 6 bar at +100 °C (for 600 hours) 4 bar at +125 °C (for 2 hours) 4 bar at +140 °C (max. test pressure) 18 bar at +40 °C
Cavitation	The following equation is valid to prevent cavitation:		$P_{abs, outlet} / P_{difference} > 5.5$

Materials in contact with medium (FDA-conform)

Sensor paddle	ETFE
Case with damming body	Brass (CuZn40PbZ), PA6T/6I (40% GF)
Sealing material	EPDM (perox.) FPM

Electrical overview

Power supply	U_{IN}	5 VDC ±5%
Output flow (Q)	Frequency Square pulse signal	$U_{OUT, Q, Frequency}$ < 0.1 ... > 4.75 V
Output temperature (T)	Resistant signal	$R_{OUT, PT1000}$ PT1000 class B DIN EN 60751 $R_{OUT, NTC}$ NTC 10 kOhm @ 25 °C; β = 4050
Electrical connection and protection class	Connector RAST 2.5 / 2.54	IP 20
Load against GND or IN	Connector M12x1	IP 65
Current consumption I_{IN} load free	Version OEM	< 6 mA
	Version standard	< 10 mA

Weight

DN 10 with thread K	~ 170 g
DN 10 with thread G	~ 250 g
DN 32	~ 650 g

Test / Admissions

Electromagnetic compatibility	acc. to EN 61326-2-3 (no protection at surge)
-------------------------------	---

Packaging

Single packaging	
Multiple packaging	

Minimum life span on high flow rate and high temperature

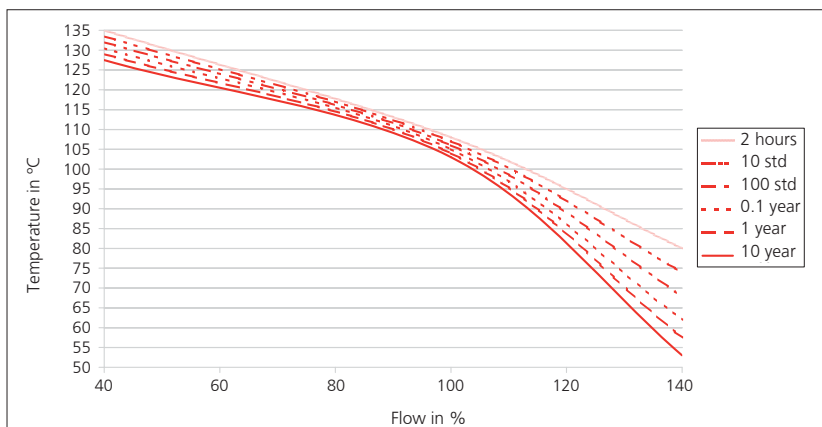

Nominal diameters dependent variables

Nominal diameters	Tube connection	Measuring range	Quantity per puls @ 50% fs	Flow range	Characteristic line frequency output	Frequency range	Pressure drop ^{1), 2)}
DN 10	K	1.8 ... 32 l/min	1.416 ml	0.265 ... 4.716 m/s	0.0860 * f - 0.2	23 ... 374 Hz	22.50 * Q ²
DN 10	G	1.8 ... 32 l/min	1.386 ml	0.295 ... 5.895 m/s	0.0847 * f - 0.2	24 ... 380 Hz	22.50 * Q ²
DN 10	K	2.0 ... 40 l/min	1.419 ml	0.265 ... 4.716 m/s	0.0860 * f - 0.2	26 ... 467 Hz	22.50 * Q ²
DN 10	G	2.0 ... 40 l/min	1.386 ml	0.295 ... 5.895 m/s	0.0840 * f - 0.2	26 ... 479 Hz	22.50 * Q ²
DN 32	K	14 ... 240 l/min	27.513 ml	0.290 ... 4.974 m/s	1.6710 * f - 1.5	9 ... 145 Hz	0.25 * Q ²

Order code selection table 235. X X X X X X X

Version	Flow		9						
	Flow and temperature (PT1000)		8			1			
	Flow and temperature (NTC)		7			1			
Nominal diameters and flow range	DN 10 1.8 ... 32 l/min.			1	0				
	DN 10 2.0 ... 40 l/min.			1	1				
	DN 32 14.0 ... 240 l/min.			3	2				K
Output / power supply	Frequency output, 0 ... 5 VDC (Square pulse signal)	5 VDC	OEM	9		0			
	Frequency output, 0 ... 5 VDC (Square pulse signal)	5 VDC	Standard			1			
Electrical connection	3-pole connector RAST 2.5			9			0		
	2x3-pole connector RAST 2.5			7,8		1	1		
	3-pole connector RAST 2.5 (condensation protection)			9			2		
	2x3-pole connector RAST 2.5 (condensation protection)			7,8		1	3		
	3-pole circular connector M12x1 (condensation protection)			9		1	4		
	5-pole circular connector M12x1 (condensation protection)			7,8		1	5		
Sealing material	EPDM Ethylene propylene rubber (peroxidically cross-linked)								1
	FPM Fluoro elastomer								2
Tube connection	Brass with outside thread K (DN 10 - G ½, DN32 - G 1 ½)								K
	Brass with outside thread G (DN 10 - G 1)								G

Accessories ³⁾

				Order number
Connector RAST 2.5 with cable	3-pole	30 cm		111668
Connector RAST 2.5 with cable	3-pole	110 cm		101817
Straight-wire box for connector M12x1 with cable	3-pole	200 cm		114605
Corner-wire box for connector M12x1 with cable	3-pole	200 cm		114604
Connector RAST 2.5 with cable	2x3 pole	110 cm	(with temperature)	114629
Straight-wire box for connector M12x1 with cable	5-pole	200 cm	(with temperature)	114564
Corner-wire box for connector M12x1 with cable	5-pole	200 cm	(with temperature)	114563
Straight-wire box for connector M12x1 screwing terminal	5-pole			115024

Dimension diagram DN 10, 32

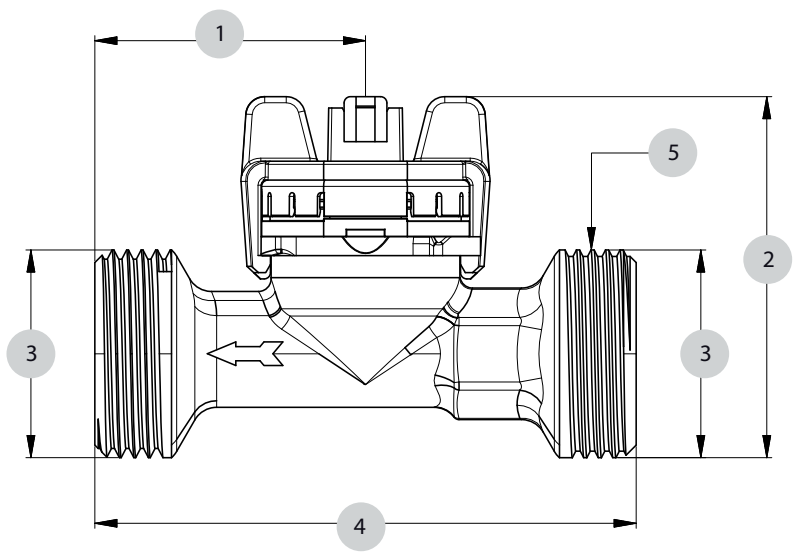

	1	2	3	4	5
DN10	43	57.3	G 1	86	∅ 19
DN32	50	74.9	G 1 ½	134	∅ 41

Consider the following to ensure the correct function of the sensor.

- Only diameter changes from large to small are allowed.
- Avoid repeated elbows in the same level at entryside

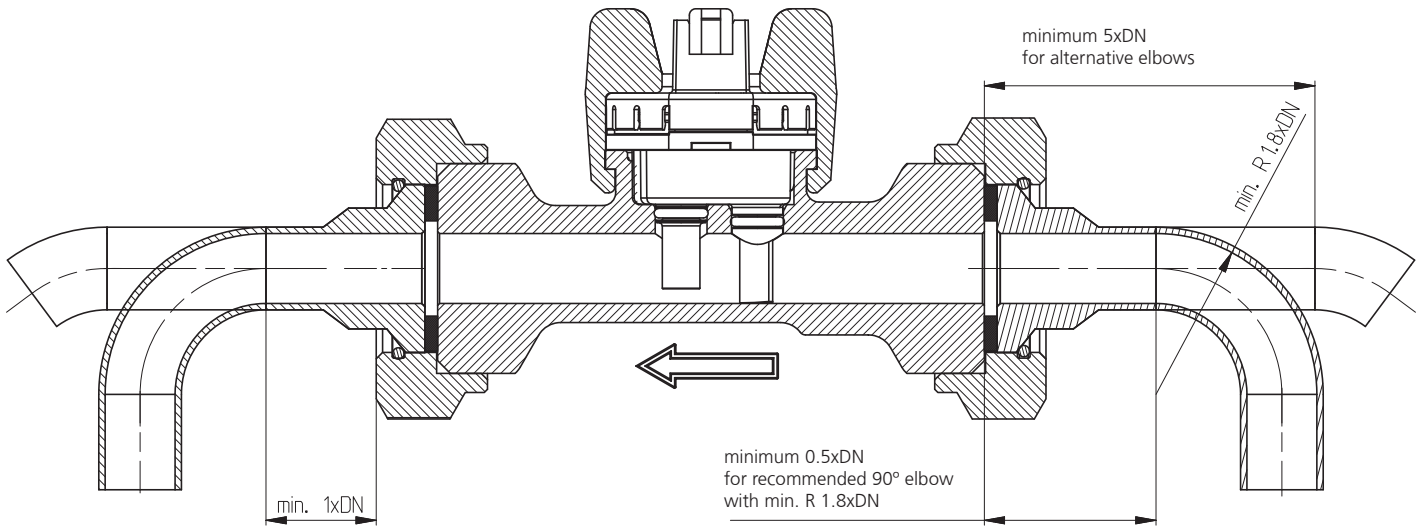

Electrical connections

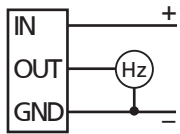

RAST 2.5 without temperature output

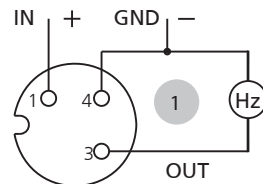
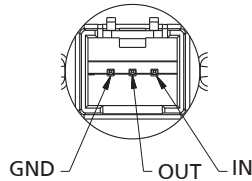

Connector M12x1 without temperature output

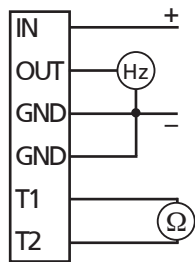

Connector 2x3-poles with temperature output

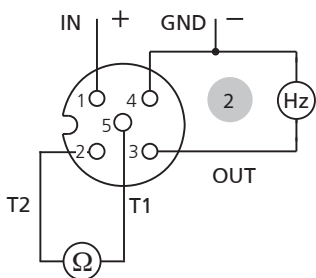
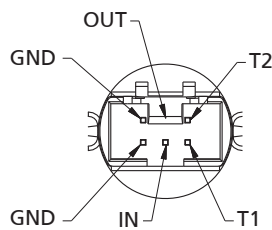

Connector M12x1 with temperature output

Pin		Colour
1	1	brown
3		blue
4		black
1	2	brown
2		white
3		blue
4		black
5		gray

Huba Control

FOR FINE PRESSURE AND FLOW MEASUREMENT

Huba Control AG
Headquarters

Industriestrasse 17
5436 Würenlos
Telefon +41 (0) 56 436 82 00
Telefax +41 (0) 56 436 82 82
info.ch@hubacontrol.com

Huba Control AG
Niederlassung Deutschland

Schlattgrabenstrasse 24
72141 Walddorfhäslach
Telefon +49 (0) 7127 23 93 00
Telefax +49 (0) 7127 23 93 20
info.de@hubacontrol.com

Huba Control SA
Succursale France

Rue Lavoisier
Technopôle Forbach-Sud
57602 Forbach Cedex
Téléphone +33 (0) 387 847 300
Télécopieur +33 (0) 387 847 301
info.fr@hubacontrol.com

Huba Control AG
Vestiging Nederland

Hamseweg 20A
3828 AD Hoogland
Telefoon +31 (0) 33 433 03 66
Telefax +31 (0) 33 433 03 77
info.nl@hubacontrol.com

Huba Control AG
Branch Office United Kingdom

Unit 13 Berkshire House
County Park Business Centre
Shrivenham Road
Swindon - Wiltshire SN1 2NR
Phone +44 (0) 1993 776667
Fax +44 (0) 1993 776671
info.uk@hubacontrol.com

www.hubacontrol.com