

Flow sensor for liquid media type 236

Flow range

1.8 ... 240 l/min

Nominal diameters

DN 10 / 32

Temperature measurement

-40 ... +125 °C



The type 236 is based on the type 210 but incorporates a brass housing. The Vortex Sensor type 236 has a rugged construction of brass connection. This flow sensor is available with a larger variety concerning power supply and outputs.

You can choose between various versions as integrated temperature measurement. With no moving parts the flow sensor is not sensitive to debris, has marginal pressure loss and high accuracy.

- Flow measuring with voltage, current or frequency output
- Temperature non-sensitive measuring principle
- Excellent media resistance (measuring element not in contact with the media)
- CE conformity
- Wide application temperature range
- Marginal loss of pressure
- Measuring element not sensitive to debris
- Direct temperature measurement in the medium

Flow measurement

Measuring principle	Vortex	Piezoelectric sensor element
Measuring range		1.8 ... 240 l/min
Nominal diameters		DN 10 / 25
Accuracy at < 50% fs (water)		< 1% fs
Accuracy at > 50% fs (water)		< 2% measuring value
Response time	Immediately	Signal delay < 100 ms
	Therefore suitable for spigot use.	Response time < 5 ms
		Frequency output
		Analogue output
		Signal delay < 2 s
		Response time < 500 ms

Temperature measurement

Measuring principle	Resistance	PT1000
	Measuring range	-40 ... +125 °C
PT1000	Accuracy	class B DIN EN 60751
		@ T = 0 °C ± 0.3 K
		@ T ≠ 0 °C ± 0.3 K ± 0.005 * T
0 ... 10 V	Measuring range	-25 ... +125 °C
	Accuracy	± 0.5 K ± 0.005 * T
	Calculation temperature	T (°C) = ±150 °C / 10 V * U _{OUT,T} - 25 °C
Temperature influences	Self-heating at temperature sensor	1 K/mW
	Conduction resistance to connector	0.8 Ohm

Operating conditions

Medium	Suitable for heating circuit water with the usual additives Drinking water	Other medium on request
temperature	Media	≤ +125 °C
	Ambient	-15 ... +85 °C
	Storage	-30 ... +85 °C
	(for lifetime)	12 bar at +40 °C
Max. pressure and medium temperature	(for lifetime)	6 bar at +100 °C
	(for 600 hours)	4 bar at +125 °C
	(for 2 hours)	4 bar at +140 °C
	(max. test pressure)	18 bar at +40 °C
Cavitation	The following equation is valid to prevent cavitation:	$P_{abs.outlet} / P_{difference} > 5.5$

Materials in contact with medium (FDA-conform)

Sensor paddle	ETFE
Case with damming body	Brass (CuZn40PbZ), PA6T/6I (40% GF)
Sealing material	EPDM (perox.) FPM

Electrical overview

		Frequency output	Voltage output	Current output
Power supply	U _{IN}	4.75 ... 33 VDC	11.5 ... 33 VDC	8 ... 33 VDC
Output	Frequency square pulse signal U _{OUT_Q_frequency}	< 0.5 ... > U _{IN} - 0.5 V	-	-
Flow (Q)	Analogue signal	U _{OUT_Q} or I _{OUT}	0 ... 10 V	4 ... 20 mA
Output	Resistant signal	R _{OUT_PT1000}	PT1000 class B DIN EN 60751	
temperature (T)	Voltage signal	U _{OUT_T}	0 ... 10 V	-
Electrical connection and protection class		M12x1 (IP 65)	M12x1 (IP 65)	M12x1 (IP 65)
Load against GND or IN		< 1 mA / < 100 nF	< 6 mA / < 100 nF ¹⁾	< (U _{IN} - 8 V) / 20 mA
Current consumption load free (I _{IN})		< 2mA	< 5 mA	-

Weight

DN 10 with thread K	~ 170 g
DN 10 with thread G	~ 250 g
DN 32	~ 650 g

Test / Admissions

Electromagnetic compatibility	CE-conform acc. to EN 61326-2-3
-------------------------------	---------------------------------

Packaging

Single packaging	
Multiple packaging	

Minimum life span on high flow rate and high temperature

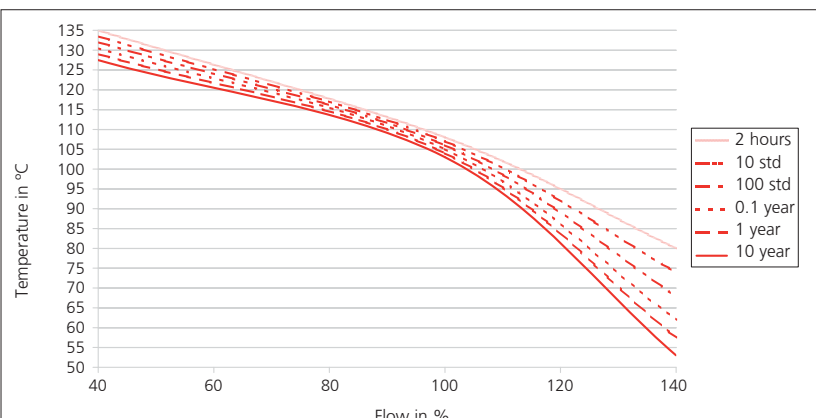

Nominal diameters dependent variables

Nominal diameters	Tube connection	Measuring range	Quantity per puls @ 50% fs	Flow range	Characteristic line frequency output	Frequency range	Characteristic line voltage output	Characteristic line current output	Pressure drop ^{1), 2)}
DN 10	K	1.8 ... 32 l/min	1.416 ml	0.265 ... 4.716 m/s	0.0860 * f - 0.2	23 ... 374 Hz	Q = 3.2 * U _{out,Q}	Q = 2.000 * (I - 4 mA)	22.50 * Q ²
DN 10	G	1.8 ... 32 l/min	1.386 ml	0.295 ... 5.895 m/s	0.0847 * f - 0.2	24 ... 380 Hz	Q = 4.0 * U _{out,Q}	Q = 2.500 * (I - 4 mA)	22.50 * Q ²
DN 10	K	2.0 ... 40 l/min	1.419 ml	0.265 ... 4.716 m/s	0.0860 * f - 0.2	26 ... 467 Hz	Q = 3.2 * U _{out,Q}	Q = 2.000 * (I - 4 mA)	22.50 * Q ²
DN 10	G	2.0 ... 40 l/min	1.386 ml	0.295 ... 5.895 m/s	0.0840 * f - 0.2	26 ... 479 Hz	Q = 4.0 * U _{out,Q}	Q = 2.500 * (I - 4 mA)	22.50 * Q ²
DN 32	K	14 ... 240 l/min	27.513 ml	0.290 ... 4.974 m/s	1.6710 * f - 1.5	9 ... 145 Hz	Q = 24 * U _{out,Q}	Q = 15.000 * (I - 4 mA)	0.25 * Q ²

Order code selection table

236. X X X X X X X

Version	Flow						9													4						
	Flow and temperature (PT1000)						8														5					
	Flow and temperature (0 ... 10 V)						6														3	5				
Nominal diameters and flow range	DN 10 1.8 ... 32 l/min.																									
	DN 10 2.0 ... 40 l/min.																									
	DN 32 14.0 ... 240 l/min.																								K	
Output and power supply	Frequency output (Square pulse signal)				4.75 ... 33 VDC							8,9														
	Analogue signal 0 ... 10 V				11.5 ... 33 VDC																					
	Analogue signal 4 ... 20 mA				8 ... 33 VDC							8,9														
Electrical connection	Connector M12x1 2- or 3-pole (condensation protection)																									
	Connector M12x1 4- or 5-pole (condensation protection)																									
Sealing material	EPDM Ethylene propylene rubber (peroxidically cross-linked)																									1
	FPM Fluoro elastomer																									2
Tube connection	Brass with outside thread K (DN 10 - G 1/2, DN32 - G 1 1/2)																									K
	Brass with outside thread G (DN 10 - G 1)																									G

Accessories³⁾

				Order number
Straight-wire box for connector M12x1 with cable	3-pole	200 cm		114605
Corner-wire box for connector M12x1 with cable	3-pole	200 cm		114604
Straight-wire box for connector M12x1 with cable	5-pole	200 cm	(with temperature)	114564
Corner-wire box for connector M12x1 with cable	5-pole	200 cm	(with temperature)	114563
Straight-wire box for connector M12x1 screwing terminal	5-pole			115024

Dimension diagram DN 10, 32

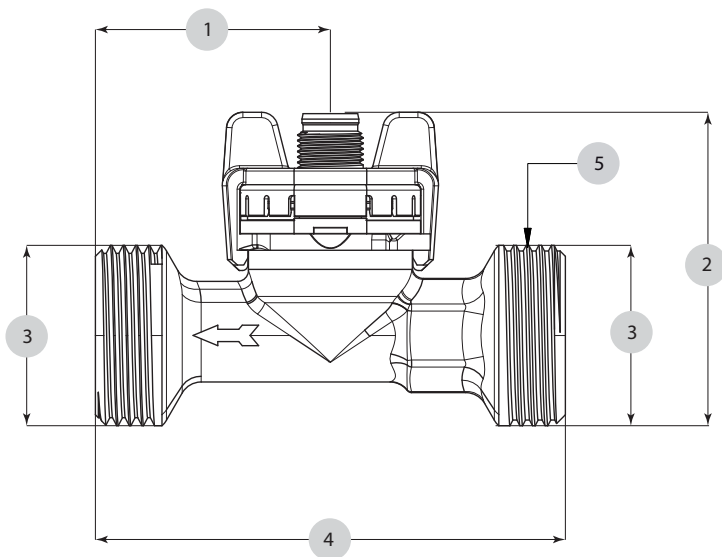

	1	2	3	4	5
DN10	43	57.3	G 1	86	19
DN32	50	74.9	G 1 1/2	134	41

Consider the following to ensure the correct function of the sensor.

- Only diameter changes from large to small are allowed.
- Avoid repeated elbows in the same level at entryside

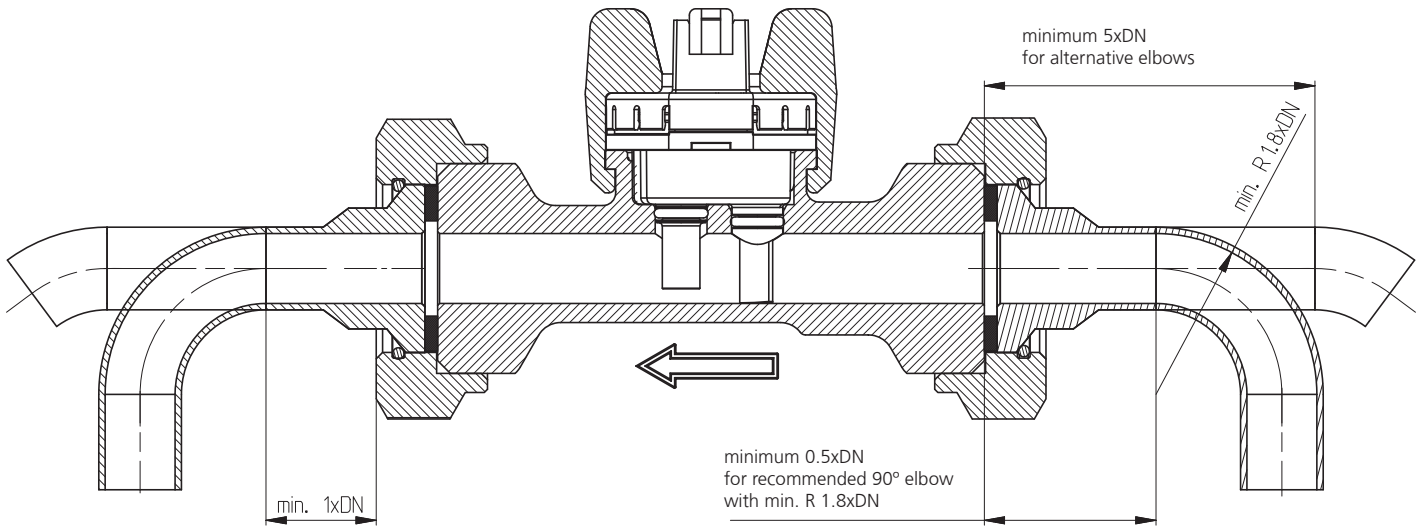

Electrical connection

Connector M12x1 without temperature measurement

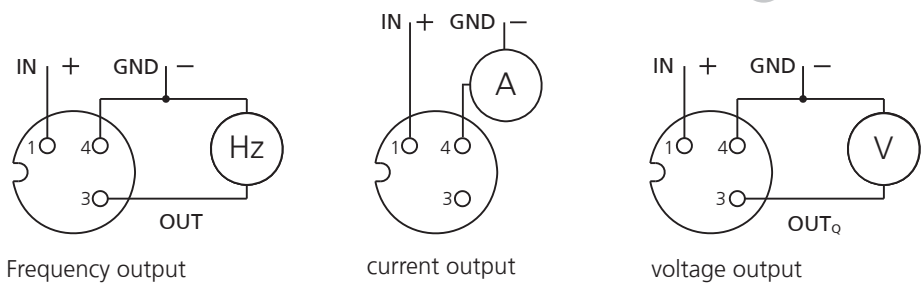

Pin	Colour
1	brown
3	blue
4	black
1	brown
2	white
3	blue
4	black
5	gray

Connector M12x1 with temperature measurement

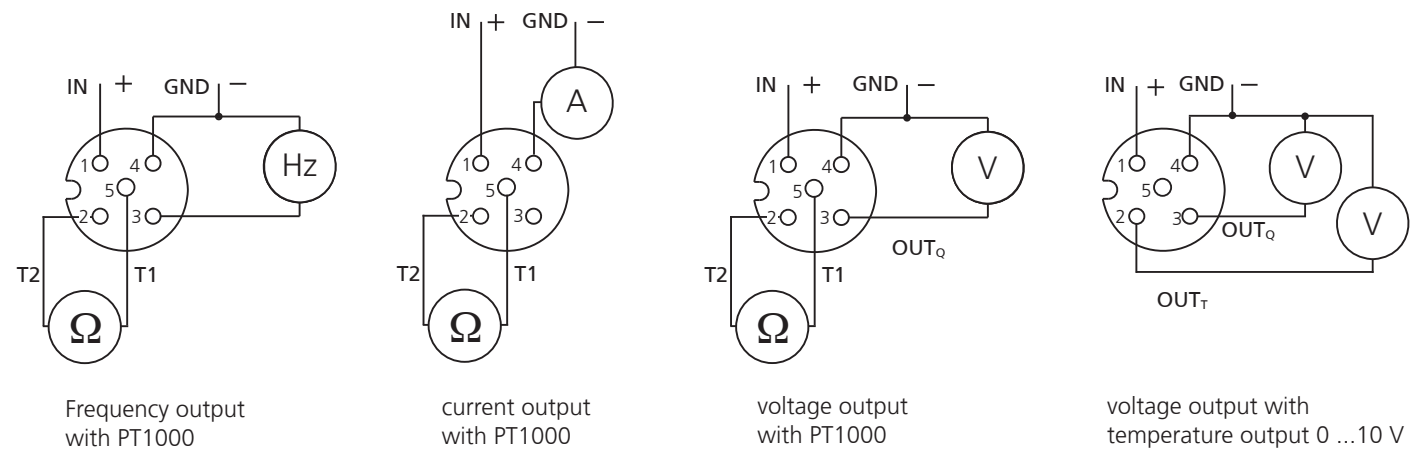

Huba Control

FOR FINE PRESSURE AND FLOW MEASUREMENT

Huba Control AG
Headquarters

Industriestrasse 17
5436 Würenlos
Telefon +41 (0) 56 436 82 00
Telefax +41 (0) 56 436 82 82
info.ch@hubacontrol.com

Huba Control AG
Niederlassung Deutschland

Schlattgrabenstrasse 24
72141 Walddorfhäslach
Telefon +49 (0) 7127 23 93 00
Telefax +49 (0) 7127 23 93 20
info.de@hubacontrol.com

Huba Control SA
Succursale France

Rue Lavoisier
Technopôle Forbach-Sud
57602 Forbach Cedex
Téléphone +33 (0) 387 847 300
Télécopieur +33 (0) 387 847 301
info.fr@hubacontrol.com

Huba Control AG
Vestiging Nederland

Hamseweg 20A
3828 AD Hoogland
Telefoon +31 (0) 33 433 03 66
Telefax +31 (0) 33 433 03 77
info.nl@hubacontrol.com

Huba Control AG
Branch Office United Kingdom

Unit 13 Berkshire House
County Park Business Centre
Shrivenham Road
Swindon - Wiltshire SN1 2NR
Phone +44 (0) 1993 776667
Fax +44 (0) 1993 776671
info.uk@hubacontrol.com

www.hubacontrol.com