

Relative pressure transmitter type 522 for shipbuilding

Pressure range
0 ... 2.5 – 600 bar



The compact type 522 pressure transmitter for shipbuilding is based upon the Huba Control developed thick film technology where the pressure measuring cell is fully welded.

The pressure measuring cell incorporates a fully welded construction within the transducer housing. Highest requirements in various applications concerning burst can be met.

All pressure transmitters of type 522 have the most important certifications for the shipbuilding industry.

- Compact, rugged construction
- Welded without sealing parts
- Certified for shipbuilding with:
 - Germanischer Lloyd
 - American Bureau of Shipping
 - Bureau Veritas
 - Det Norske Veritas
 - Lloyd's Register

Technical overview

Pressure range

Relative	0 ... 2.5 – 600 bar
----------	---------------------

Operating conditions

Medium	Liquids, gases and refrigerants (incl. ammonia)	
Temperature	Medium	-40 ... +135 °C
	Ambient	-30 ... +85 °C
	Storage	-50 ... +100 °C
Tolerable overload	≤ 6 bar	5 x FS
	> 6 bar	3 x FS (max. 1500 bar)
Rupture pressure	≤ 6 bar	10 x FS
	> 6 bar	6 x FS (max. 2500 bar)

Materials

Cover	Stainless steel 1.4404 / AISI 316L	
Plug accommodation	Polyarylamide 50% GF V0	
Materials in contact with medium	Pressure connection	Stainless steel 1.4404 / AISI 316L
	Sensor	Stainless steel

Electrical overview

	Output	Power supply	Load	Current consumption
2 wire	4 ... 20 mA	7 ... 33 VDC	$< \frac{\text{supply voltage} - 7\text{V}}{0.02\text{A}}$ [Ohm]	< 23 mA
2 wire (Ex)	4 ... 20 mA	10 ... 30 VDC	$< \frac{\text{supply voltage} - 10\text{V}}{0.02\text{A}}$ [Ohm]	< 23 mA
3 wire	0 ... 10 V	12 ... 33 VDC	>10 kOhm / < 100 nF	< 7 mA
Polarity reversal protection	Short circuit proof and protected against polarity reversal. Each connection is protected against crossover up to max. supply voltage.			

Protection class

Protection class III

Dynamic response

Response time	< 2 ms, 1 ms typ.
Load cycle	< 100 Hz

Protection standard

Connector DIN EN 175301-803-A	IP 65
Swift connector, Connector M12x1	IP 67

Electrical connection

Swift connector with cable 1.5 m (PVC spec.)
Connector DIN EN 175301-803-A
Connector M12x1

Pressure connection

Inside thread	7/16 - 20 UNF	
	1/2 - 14 NPT	
Outside thread	7/16 - 20 UNF	sealed at back DIN 3852 form E with Profile seal ring in FPM spec. (-30 ... +135 °C)
	1/4 -18 NPT	sealed at back and manometer (combi) with Profile seal ring in FPM spec. (-30 ... +135 °C)
	G 1/4	
	G 1/2	
	M20x1.5	
	G 1/2	sealed at front

Installation arrangement

Unrestricted

Tests / Admissions

Electromagnetic compatibility	CE conformity acc. EN 61326-2-3
Shock acc. IEC IEC 68-2-27	100 g, 11 ms half sine wave, all 6 directions, free fall from 1 m on concrete (6x)
Constant shock acc. IEC 68-2-29	40 g for 6 ms, 1000x all 3 directions
Vibration acc. IEC 68-2-6	20 g, 15 ... 2000 Hz, 15 ... 25 Hz with amplitude ± 15 mm, 1 Octave/min. all 3 directions, 50 constant load
Shipbuilding	Germanischer Lloyd
	American Bureau of Shipping
	Bureau Veritas
	Det Norske Veritas
	Lloyd's Register

Protection against explosion

Intrinsic safety "i" (with current output only)	Ex II 1/2 G Ex ia IIC T4 Ga/Gb
EC type examination certificate	Ex II 1/2 D Ex ia IIC T125°C Da/Db
Connection to certified intrinsically safe resistive circuits with maximum values	SEV 10 ATEX 0145
Effective internal inductance and capacitance for versions with plugs complying with EN 175301-803-A or M12x1	Ui = 30 VDC; li = 100 mA = Pi = 0.75 W
	Li = 0 nH; Ci = 0 nF

Weight

~ 90 g

Packaging (Please state on order)

Single packaging in cardboard	accessories integrated
Multiple packaging in cardboard (25 pcs)	

Order code selection table in psi		522.9 X X X X X X X X X X																		
Pressure range ¹⁾	0 ... 30 psi	B	4	S	0															
	0 ... 60 psi	B	5	S	0															
	0 ... 100 psi	B	7	S	0															
	0 ... 200 psi	C	1	S	0															
	0 ... 300 psi	C	2	S	0															
	0 ... 500 psi	C	3	S	0															
	0 ... 750 psi	D	0	S	0															
	0 ... 1000 psi	D	1	S	0															
	0 ... 2000 psi	D	2	S	0															
	0 ... 3000 psi	D	3	S	0															
	0 ... 5000 psi	E	4	S	0															
0 ... 7500 psi	E	5	S	0																
Output / power supply	0 ... 10 V												2							
	4 ... 20 mA												3							
	4 ... 20 mA	12 ... 33 VDC											4	1,3						
Electrical connection	Connector DIN EN 175301-803-A ²⁾													1						
	Connector M12x1 ²⁾	2w: IN=1 / OUT=3	3w: IN=1 / OUT=4 / GND=3											3						
	Connector M12x1 ²⁾	2w: IN=1 / OUT=4	3w: IN=1 / OUT=3 / GND=4											M						
	Swift connector with cable 1.5 m													L						
Pressure connection	Inside thread	7/16 - 20 UNF																K	0	1
	Inside thread	1/2 - 14 NPT (≤ 750 psi)																D	0	1
	Outside thread	7/16 - 20 UNF																2	0	1
	Outside thread	1/4 - 18 NPT																3	0	1
	Outside thread	G 1/4 sealed at back DIN 3852 form E with Profile seal ring in FPM spec. (-30 ... +135 °C)																4	0	1
	Outside thread	G 1/2 sealed at back and manometer (combi) with Profile seal ring in FPM spec. (-30 ... +135 °C)																8	0	1
	Outside thread	M20x1.5																E	0	1
	Outside thread	G 1/2 sealed at front																9	0	1
Pressure range variation (optional)	Indicate W and state range on order (e.g.: W0... + 400psi/OUT1...8V)																			W

Order code selection table in MPa		522.9 X X X X X X X X X X																			
Pressure range ¹⁾	0 ... 0.25 MPa	G	4	S	0																
	0 ... 0.4 MPa	G	5	S	0																
	0 ... 0.6 MPa	G	7	S	0																
	0 ... 1 MPa	H	0	S	0																
	0 ... 1.6 MPa	H	1	S	0																
	0 ... 2.5 MPa	H	2	S	0																
	0 ... 4 MPa	H	3	S	0																
	0 ... 6 MPa	K	0	S	0																
	0 ... 10 MPa	K	1	S	0																
	0 ... 16 MPa	K	2	S	0																
	0 ... 25 MPa	K	3	S	0																
	0 ... 40 MPa	L	4	S	0																
	0 ... 60 MPa	L	5	S	0																
	Output / power supply	0 ... 10 V																			
4 ... 20 mA																					
4 ... 20 mA		12 ... 33 VDC												4	1,3						
Electrical connection	Connector DIN EN 175301-803-A ²⁾																				
	Connector M12x1 ²⁾	2w: IN=1 / OUT=3	3w: IN=1 / OUT=4 / GND=3																		
	Connector M12x1 ²⁾	2w: IN=1 / OUT=4	3w: IN=1 / OUT=3 / GND=4																		
	Swift connector with cable 1.5 m																				
Pressure connection	Inside thread	7/16 - 20 UNF																	K	0	1
	Inside thread	1/2 - 14 NPT (≤ 6 MPa)																	D	0	1
	Outside thread	7/16 - 20 UNF																	2	0	1
	Outside thread	1/4 - 18 NPT																	3	0	1
	Outside thread	G 1/4 sealed at back DIN 3852 form E with Profile seal ring in FPM spec. (-30 ... +135 °C)																	4	0	1
	Outside thread	G 1/2 sealed at back and manometer (combi) with Profile seal ring in FPM spec. (-30 ... +135 °C)																	8	0	1
	Outside thread	M20x1.5																	E	0	1
	Outside thread	G 1/2 sealed at front																	9	0	1
Pressure range variation (optional)	Indicate W and state range on order (e.g.: W0... + 0.5MPa/OUT1...8V)																			W	

¹⁾ Other pressure ranges on request <http://www.sensor-ic.com/> TEL: 0755-83376489 FAX: 0755-83376182 E-MAIL:szss20@163.com

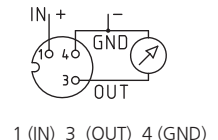
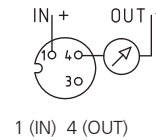
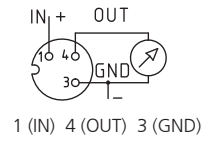
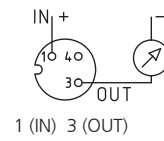
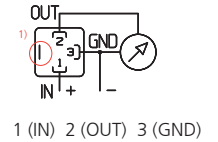
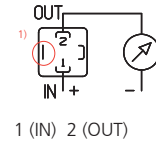
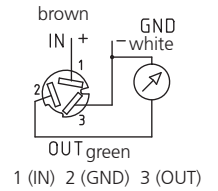
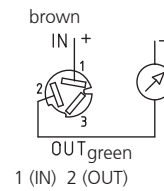
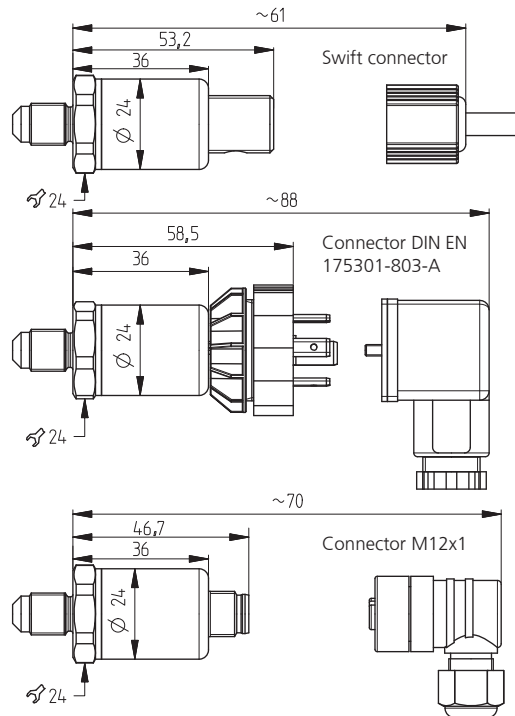
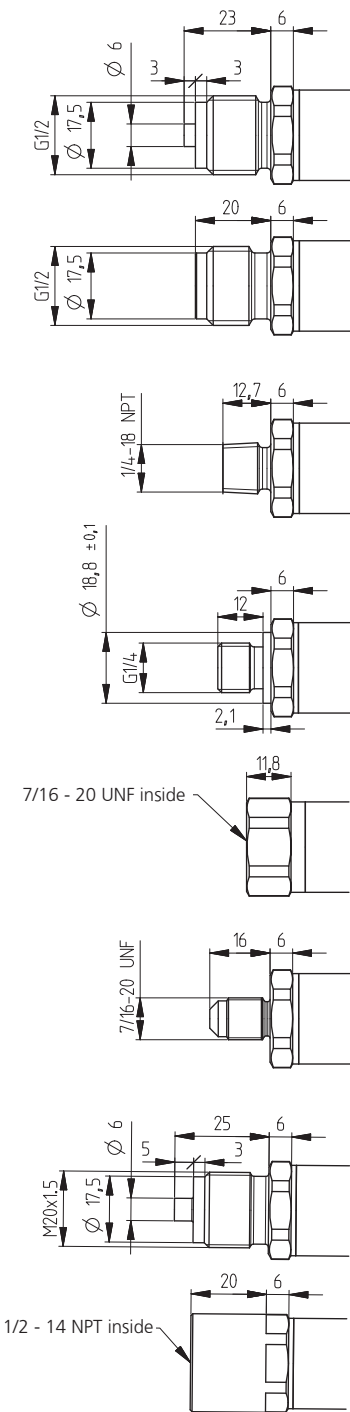

Ex

Device design with explosion protection: 4 ... 20 mA
The grounding connection is conductively connected to the transmitter housing.

Connector DIN
EN 175301-803-A (Ex)

1 (IN) 2 (OUT)

Connector M12x1 (Ex)

1 (IN) 3 (OUT) 4 (↓)

¹⁾ Not connected with transmitter housing



FOR FINE PRESSURE AND FLOW MEASUREMENT

Huba Control AG
Headquarters

Industriestrasse 17
5436 Würenlos
Telefon +41 (0) 56 436 82 00
Telefax +41 (0) 56 436 82 82
info.ch@hubacontrol.com

Huba Control AG
Niederlassung Deutschland

Schlattgrabenstrasse 24
72141 Walddorfhäslach
Telefon +49 (0) 7127 23 93 00
Telefax +49 (0) 7127 23 93 20
info.de@hubacontrol.com

Huba Control SA
Succursale France

Rue Lavoisier
Technopôle Forbach-Sud
57602 Forbach Cedex
Téléphone +33 (0) 387 847 300
Télécopieur +33 (0) 387 847 301
info.fr@hubacontrol.com

Huba Control AG
Vestiging Nederland

Hamseweg 20A
3828 AD Hoogland
Telefoon +31 (0) 33 433 03 66
Telefax +31 (0) 33 433 03 77
info.nl@hubacontrol.com

Huba Control AG
Branch Office United Kingdom

Unit 13 Berkshire House
County Park Business Centre
Shrivenham Road
Swindon Wiltshire SN1 2NR
Phone +44 (0) 1993 776667
Fax +44 (0) 1993 776671
info.uk@hubacontrol.com

www.hubacontrol.com