

Level sensing relative and absolute pressure transmitter type 712

Pressure range
0 ... 0.3 - 3 bar



The level sensing pressure transmitter Type 712 is manufactured using an relative or absolute pressure measuring cell with an adjusted and amplified sensor signal and is available with various cable lengths from 2 to 30 meters. The Type 712 offers Ex protection as well as versions with integrated temperature measurement.

In addition to voltage and current outputs the Type 712 is available with ratiometric outputs.

- suitable for drinking water
- intrinsically safe execution with voltage- and current output
- with integrated temperature measurement
- suitable for fitting in 1-inch pipe

Technical overview**Pressure range**

Relative	0.0 ... 0.3 – 2.5 bar
Absolute	0.8 ... 1.4 – 3.0 bar

Operating conditions

Medium	Fuel oil, ultra-light ¹⁾	SN 181 160-2
	Fuel oil, heavy ¹⁾	SN 181 160-2
	Diesel oil ¹⁾	
	Benzine ¹⁾	
	Water	
Temperature	Medium and ambient	-20 ... +80 °C
	Storage	-40 ... +80 °C
Overload		3x fs; max. 3 bar at 0.3 bar version

Materials in contact with medium

Case	Stainless steel 1.4404 / AISI 316L
Sensor	Ceramik Al ₂ O ₃
Cable	PE-HD
Protection cover	PPE
Sealing material	FPM, EPDM (for drinking water)

Electrical overview

	Output	Power supply	Load	Current consumption
2 wire	4 ... 20 mA	10 ... 30 VDC	$< \frac{\text{Power supply} - 7V}{0.02A}$ [Ohm]	< 20 mA
3 wire	0 ... 10 V	12 ... 30 VDC	>10 kOhm / < 100 nF	< 5 mA
	ratiom. 10 ... 90%	5 VDC ±10%	> 5 kOhm / < 100 nF	< 3 mA
4 wire (with temperature)	ratiom. 10 ... 90%	5 VDC ±10%	> 5 kOhm / < 100 nF	< 3 mA
Polarity reversal protection	Short circuit proof and protected against polarity reversal.			
Temperature output			> 1 MOhm	

Dynamic response

Response time	< 2 ms
---------------	--------

Protection standard

IP 68	
-------	--

Runtime

Time starts at the moment of application of minimal supply voltage	< 10 ms
--	---------

Electrical connection

Cable PE-HD	length 2, 5, 10, 15, 20, 30 m
-------------	-------------------------------

Test / Admissions

Electromagnetic compatibility	CE-conform acc. to EN 61326-2-3
Drinking water approval	applied

Ex-protection

IECEx SEV 12.006	Ex ia IIC T4 Ga
SEV 12 ATEX 0138	II 1 G Ex ia IIC T4 Ga

Weight

Without cable	~ 200 g
---------------	---------

Packaging

Single packaging	
------------------	--

Accuracy**Standard**

Parameter	Unit	
Characteristic line ²⁾ (at 25°C)	% fs	± 0.8
Resolution ³⁾	% fs	0.1
Thermal characteristic ^{4), 5)}	% fs/10K	± 0.2

Higher accuracy (only with ratiometric execution and pressure range ≥ 1 bar)

Parameter	Unit	
Characteristic line ²⁾ (at -10 ... +60°C)	% FS	± 0.5
Resolution	% FS	0.1

¹⁾ Ex-protection to attention!²⁾ incl. zero point, full scale, linearity, hysteresis and repeatability)³⁾ pressure range 0.3 bar < 0.2 % fs⁴⁾ at -20 ... +80 °C⁵⁾ 0.3 bar-type with output 4 - 20 mA ± 0.5% fs/10K

Order code selection table				712	X	X	X	X	X	X	X	X	X	X	X	
Pressure mode	Absolute			8												
	Relative			9												
	Absolute with higher accuracy			C				1,2								
	Relative with higher accuracy			D				1,2								
Pressure range ¹⁾			Pmax.													
	0.0 ... 0.3 bar	relative pressure	4.5 bar	9	1	3		0,1,2								
	0.0 ... 1.0 bar	relative pressure	4.5 bar	9,D	1	1										
	0.0 ... 1.6 bar	relative pressure	6.0 bar	9,D	1	2										
	0.0 ... 2.5 bar	relative pressure	9.0 bar	9,D	1	4										
			Max measurable level (for water depending on the locations weather)													
	0.8 ... 1.4 bar	absolute pressure	4.5 bar	3.5 ... 6.7 mWs	8	1	1									
0.8 ... 2.0 bar	absolute pressure	6.0 bar	9.6 ... 12.8 mWs	8,C	1	2										
0.8 ... 3.0 bar	absolute pressure	9.0 bar	20.0 ... 23.0 mWs	8,C	1	4										
▲ Full scale signal at these pressures																
● P _{BARO} = 1060 mbar (high pressure on sea level)																
● P _{BARO} = 740 mbar (low pressure at 2000 meters above sea level)																
Sealing material	FPM	Fluoro-elastomer						0								
	EPDM	Ethylene propylene (for drinking water)						1								
Output / power supply	4 ... 20 mA		10 ... 30 VDC					0								
	ratiom. 10 ... 90% 5 VDC ±10%							1								
	ratiom. 10 ... 90% 5 VDC ±10% (with temperature)							2								
	0 ... 10 V		12 ... 30 VDC					3						0		
Electrical connection ²⁾	Cable	2 m														
	Cable	5 m														
	Cable	10 m														
	Cable	15 m														
	Cable	20 m														
	Cable	30 m														
Protection cover	without protection													2	0	
	with protection													2	1	
Ex-protection	without ex-protection														0	
	ex protection Zone 0 II 1G Ex ia IIC T4 Ga and Ex ia IIC T4 Ga															4
Pressure range variation (optional)	Indicate W and state range on order (e.g.: W0... + 2bar/OUT0...10V)														W	

Dimensions in mm / Electrical connections

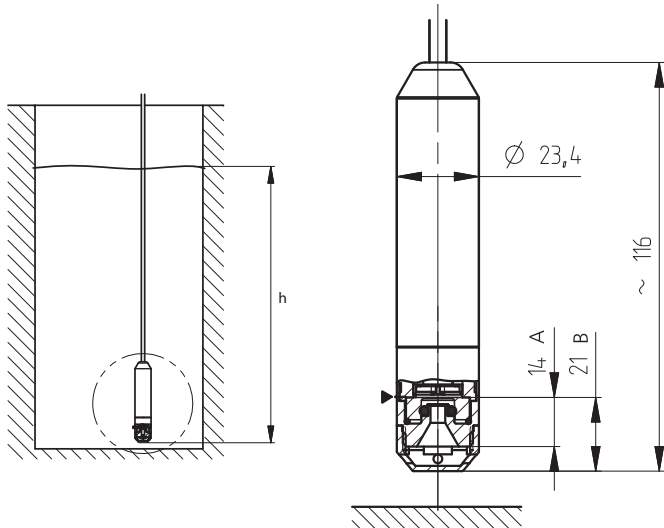

h - Fluid level
 ► - Measurement reference height
 A - Distance from protection cover to the position of measuring diaphragm
 B - distance from beginning of thread to the position of measuring diaphragm (versions without protection cover)

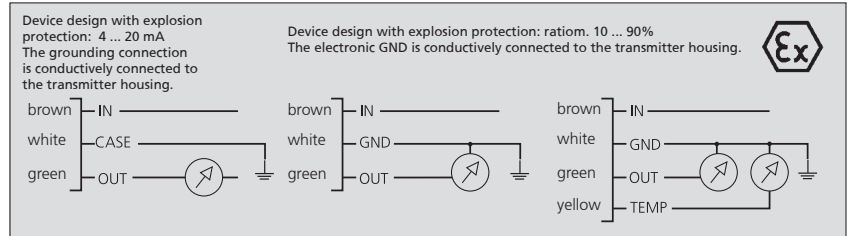
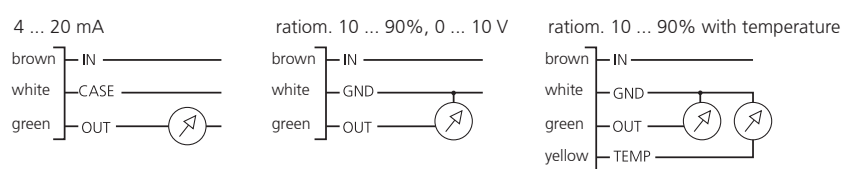

General level with relative pressure sensor:
$$h = \frac{\Delta p}{\rho \cdot g}$$

General level with absolute pressure sensor:
$$h = \frac{P_{TS} - P_{Baro}}{\rho \cdot g}$$

which
$$P_{TS} = \frac{U_{TS} - U_{TS_NP}}{U_{TS_EW} - U_{TS_NP}} \cdot (P_{TS_EW} - P_{TS_NP}) + P_{TS_NP}$$

and
$$P_{Baro} = \frac{U_{Baro} - U_{Baro_NP}}{U_{Baro_EW} - U_{Baro_NP}} \cdot (P_{Baro_EW} - P_{Baro_NP}) + P_{Baro_NP}$$
 Using a second level sensor as barometric air pressure sensor

For level sensor with current output use nominal signal values for I_{TS} ... instead of variables U_{TS} ... (resp. I_{Baro} ... instead of U_{Baro} ...)

Simplification of formula for level sensor with ratiometric output:

$$P_{TS} = \frac{U_{TS} - 0.1 \cdot U_{IN}}{0.8 \cdot U_{IN}} \cdot (P_{TS_EW} - P_{TS_NP}) + P_{TS_NP}$$

$$P_{Baro} = \frac{U_{Baro} - 0.1 \cdot U_{IN}}{0.8 \cdot U_{IN}} \cdot (P_{Baro_EW} - P_{Baro_NP}) + P_{Baro_NP}$$
 Using a second level sensor as barometric air pressure sensor

Legend:

h	level [m]	ρ	density of media [kg/m ³]
		g	acceleration of fall 9.80665 [m/s ²]
Δp	measured relative pressure [Pa]	U_{TS}	signal on level sensor output [V or mA]
P_{TS}	measured pressure of level sensor [Pa]	U_{Baro}	Signal on barometer output [V or mA]
P_{Baro}	measured pressure of barometer [Pa]	P_{TS_NP}	minimal nominal pressure of level sensor [Pa]
		P_{TS_EW}	maximum nominal pressure of level sensor [Pa]
P_{TS_NP}	minimal nominal pressure of level sensor [Pa]	U_{TS_NP}	minimal nominal signal of level sensor [V or mA]
P_{TS_EW}	maximum nominal pressure of level sensor [Pa]	U_{TS_EW}	maximum nominal signal of level sensor [V or mA]
P_{Baro_NP}	minimal nominal pressure of barometer [Pa]	U_{Baro_NP}	minimal nominal signal of barometer [V or mA]
P_{Baro_EW}	maximum nominal pressure of barometer [Pa]	U_{Baro_EW}	maximum nominal signal of barometer [V or mA]

Specification temperature output

$$T_{TEMP} = T_0 + 1 \left/ \left(a + b \cdot \ln \left(R \cdot \left[\frac{U_{IN}}{U_{TEMP}} - 1 \right] \right) + c \cdot \ln \left(R \cdot \left[\frac{U_{IN}}{U_{TEMP}} - 1 \right] \right)^3 \right) \right.$$

a = 0.001204001
b = 0.000208775
c = 0.000000294

Temperature NTC [°C]
T₀ -273.15 [°C]

U_{TEMP} Voltage NTC [V]
R 20'000 [Ω]
U_{IN} 4.5 ... 5.5 [V]

T_{TEMP} = f(U_{TEMP})

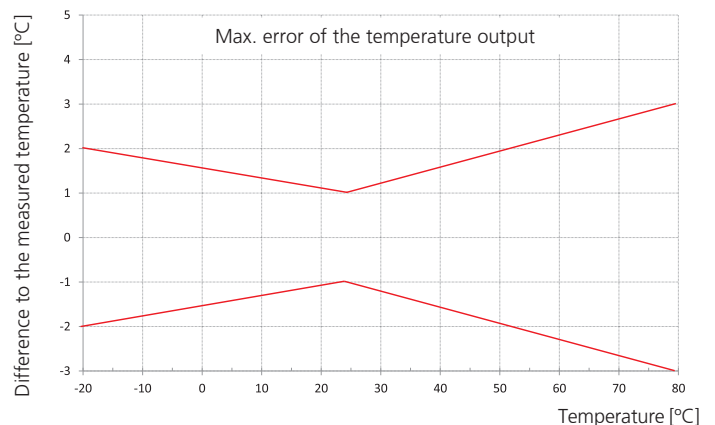
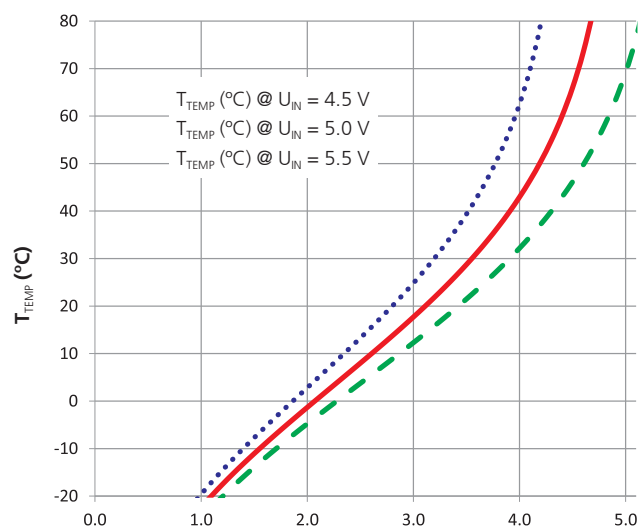

Huba Control

FOR FINE PRESSURE AND FLOW MEASUREMENT

Huba Control AG
Headquarters

Industriestrasse 17
5436 Würenlos
Telefon +41 (0) 56 436 82 00
Telefax +41 (0) 56 436 82 82
info.ch@hubacontrol.com

Huba Control AG
Niederlassung Deutschland

Schlattgrabenstrasse 24
72141 Walddorfhäslach
Telefon +49 (0) 7127 23 93 00
Telefax +49 (0) 7127 23 93 20
info.de@hubacontrol.com

Huba Control SA
Succursale France

Rue Lavoisier
Technopôle Forbach-Sud
57602 Forbach Cedex
Téléphone +33 (0) 387 847 300
Télécopieur +33 (0) 387 847 301
info.fr@hubacontrol.com

Huba Control AG
Vestiging Nederland

Hamseweg 20A
3828 AD Hoogland
Telefoon +31 (0) 33 433 03 66
Telefax +31 (0) 33 433 03 77
info.nl@hubacontrol.com

Huba Control AG
Branch Office United Kingdom

Unit 13 Berkshire House
County Park Business Centre
Shrivenham Road
Swindon Wiltshire SN1 2NR
Phone +44 (0) 1993 776667
Fax +44 (0) 1993 776671
info.uk@hubacontrol.com

www.hubacontrol.com