

The **MiniSense 100** is a low-cost cantilever-type vibration sensor loaded by a mass to offer high sensitivity at low frequencies. Pins are designed for easy installation and are solderable. Horizontal and vertical mounting options are offered. The active sensor area is shielded for improved RFI/EMI rejection. Rugged, flexible PVDF sensing element withstands high shock overload. Sensor has excellent linearity and dynamic range, and may be used for detecting either continuous vibration or impacts.

The mass may be modified to obtain alternative frequency response and sensitivity selection (consult factory).

The **MiniSense 100** acts as a cantilever-beam accelerometer. When the beam is mounted horizontally, acceleration in the vertical plane creates bending in the beam, due to the inertia of the mass at the tip of the beam. Strain in the beam creates a piezoelectric response, which may be detected as a charge or voltage output across the electrodes of the sensor.

The sensor may be used to detect either continuous or impulsive vibration or impacts. For excitation frequencies below the resonant frequency of the sensor, the device

produces a linear output governed by the "baseline" sensitivity. The sensitivity at resonance is significantly higher. Impacts containing high-frequency components will excite the resonance frequency, as shown in the plot above (response of **MiniSense 100** to a single half-sine impulse at 100 Hz, of amplitude 0.9 g). The ability of the sensor to detect low frequency motion is strongly influenced by the external electrical circuit, as described below (see "Electrical Description").

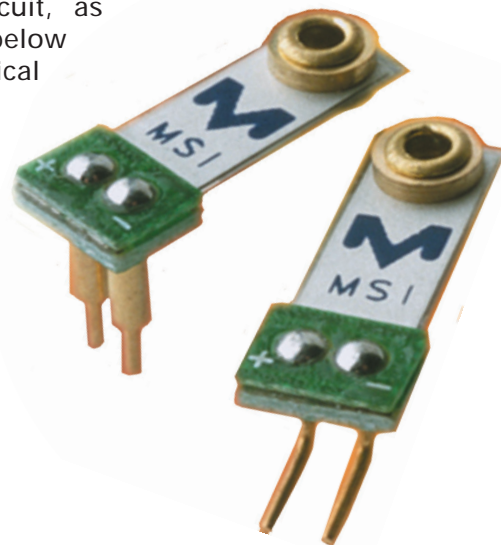

Outline Mechanical Dimensions

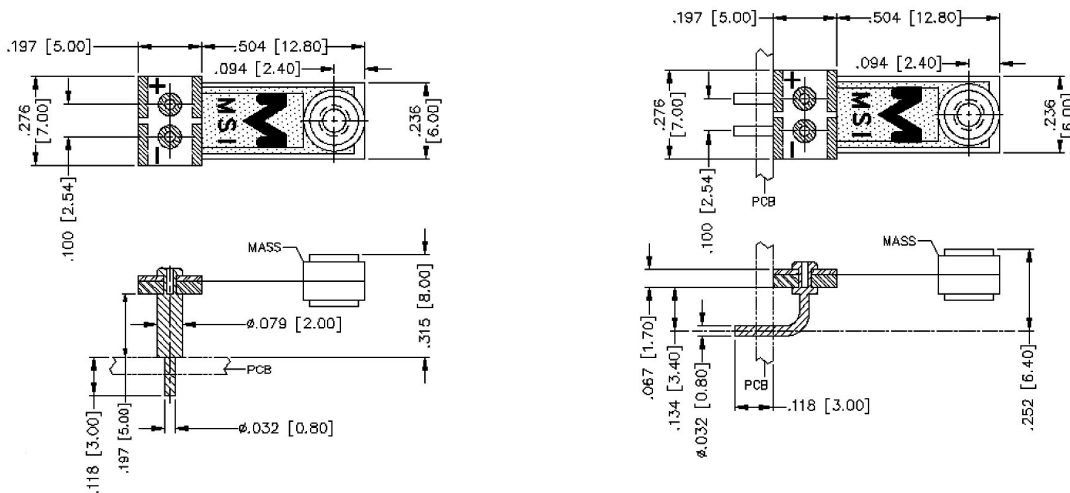

Electrical Description

The **Minisense 100** behaves electrically as an "active" capacitor: it may be modelled as a perfect voltage source (voltage proportional to applied acceleration) in series with the quoted device capacitance. Any external input or load resistance will form a high-pass filter, with a roll-off frequency as tabulated above, or calculated from the formula $f(c) = 1/(2 RC)$. The impedance of the sensor is approximately 650 M ohm at 1 Hz. The active sensor element is electrically shielded, although care should be taken in the PCB design to keep unshielded traces as short as possible.

Description	Part Number
MiniSense 100 (Horizontal)	1005939-1
MiniSense 100 (Vertical)	1005940-1

Please contact factory for custom part quotations and volume pricing.

Dec. 8, 03