



**Nemoto Sensor
Engineering Co., Ltd**

Nemoto (Europe) B.V.
Burgemeester Haspelslaan 53
1181NB, Amstelveen
The Netherlands
Tel +31 20 670 3858
Fax +31 20 670 2709
www.nemoto.eu



Technical Information

Electrochemical Chlorine Gas Sensor

NE4-C12

For Industrial Application

〒168-0072 4-10-9, Takaido-higashi, Suginami-ku, Tokyo

Nemoto Sensor Engineering Co., Ltd.

TEL. 81-3-3333-2760

FAX. 81-3-3333-7344

E-mail sensor2@nemoto.co.jp

URL <http://www.nemoto.co.jp/>



1. General

Nemoto NE4 series sensors were developed for industrial applications, and NE4-Cl₂ is a newly developed electrochemical chlorine gas sensor. Shape and pin positions are compatible with others, but the stability, repeatability, durability and reliability are superior to others, however the price is competitive with others. Features and applications are as follows.

2. Detection principle

Electrochemical sensor consists of working electrode on which oxidization or reduction takes place, counter electrode on which reduction or oxidization takes place, and reference electrode which can monitor and keep the voltage at constant. Structure of electrochemical sensor is shown in the following figure, chlorine gas diffuses through membrane into working electrode, and is reduced to hydrogen chloride at working electrode. Consequently adsorbed chlorine receives proton at working electrode, and then, hydrogen chloride is generated at this reaction. Water molecule proceeds to counter electrode, and is reduced at counter electrode by generated current of this serial reaction. Total reaction is in the below described. Cl₂ gas concentration is proportional to the current that is generated by this serial reaction.

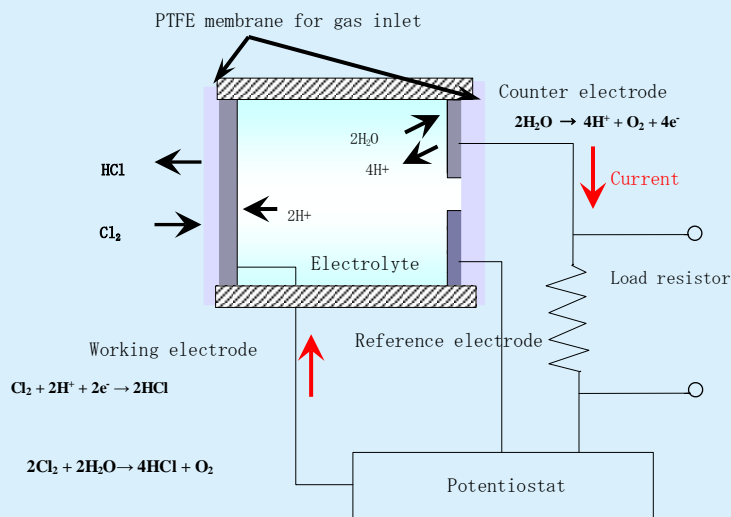

3. Features

- Quick response
- Excellent selectivity
- Good linearity and stability
- High reliability
- Excellent durability against high temperature and humidity

4. Detected gas

Chlorine

5. Application

- Cl₂ gas densitometer for industrial application
- Cl₂ gas alarm at water sterilizer



6. Dimensions and appearance

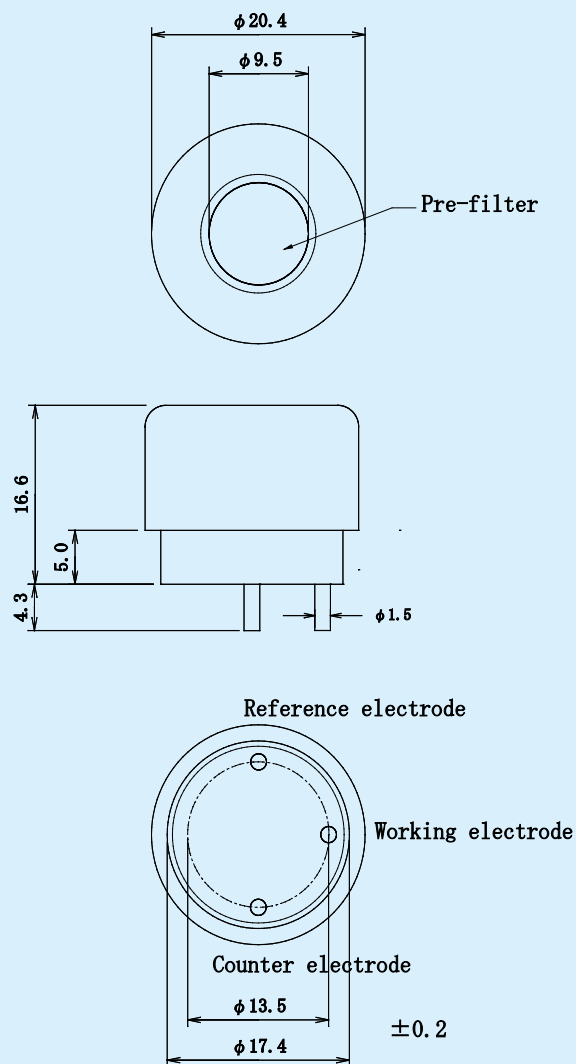

Case Material	PPO
Cap Color	Lemon yellow
Weight	5 g (approx.)

Fig.1: Appearance and dimensions of NE4-C12



7. Ratings

- | | |
|--|--|
| 1) Ambient temperature and humidity in operation | Temperature : -20 - +50 °C
Humidity : 15 - 90% RH |
| 2) Recommended ambient and humidity in storage | Temperature : 0 - 20 °C
Humidity : 15 - 90 %RH |
| 3) Operating pressure range | 0.9 - 1.1 atm |
| 4) Detection range | 0 - 10ppm |
| 5) Maximum overload | 50ppm |
| 6) Recommended load resistor | 33 ohm |

8. Specifications

- | | |
|---|--|
| 1) Output signal | 600 +/-150nA/ppm of Cl2
(Contrary signal to other models) |
| 2) Zero offset in clean air | < +/- 0.2ppm equivalent |
| 3) Response time (T90) | Less than 40sec. |
| 4) Repeatability in the same day | Less than 2% of signal |
| 5) Zero offset drift at 20 degree C | Less than 0.2ppm of Cl2 |
| 6) Zero offset temperature dependence (20 ~ +50 °C) | Less than 0.5ppm of Cl2 |
| 7) Minimum detection range | 0.1ppm |
| 8) Sensitivity reduction in long term | Less than 2% signal loss/month |
| 9) Expected lifetime | 24 months |
| 10) Recommended storage time | Less than 6 months |

9. Electrical properties

9-1. Typical Gas Sensitivity

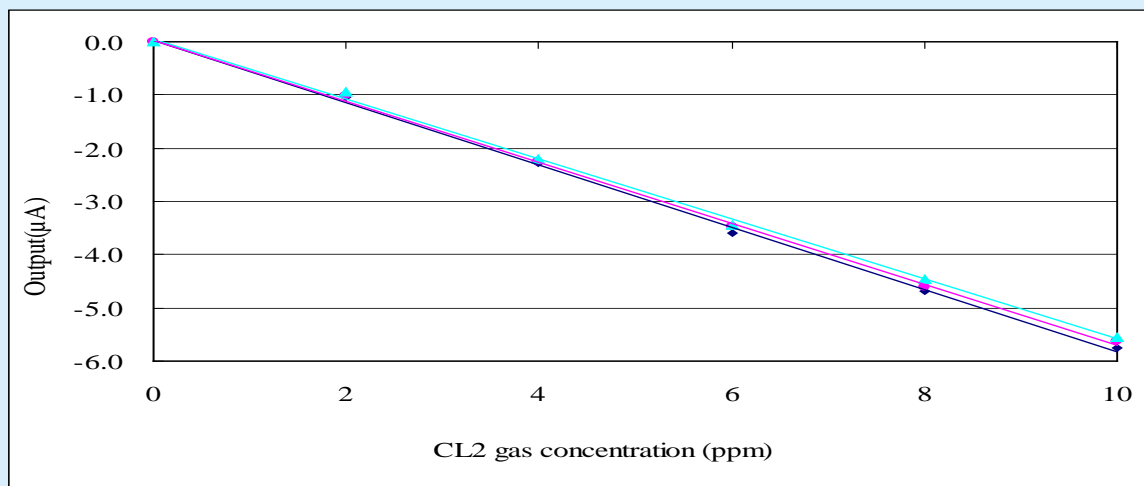

Fig.2: Gas Sensitivity of NE4-Cl2



9-2. Cross Sensitivity

Table1: Cross Sensitivity of NE4-CI2

Detected gases	Relative sensitivity (Sensitivity to CI2 is 100.)
Chlorine	100
Carbon monoxide	Almost 0
Carbon dioxide	0
Hydrogen	Almost 0
Nitrogen dioxide	100
Sulfur-dioxide	Less than -15
Nitrogen monoxide	Less than 2
Hydrogen sulfide	Less than -100
Ammonia	0
Ethanol	Almost 0
Toluene	0

9-3. Zero temperature dependence

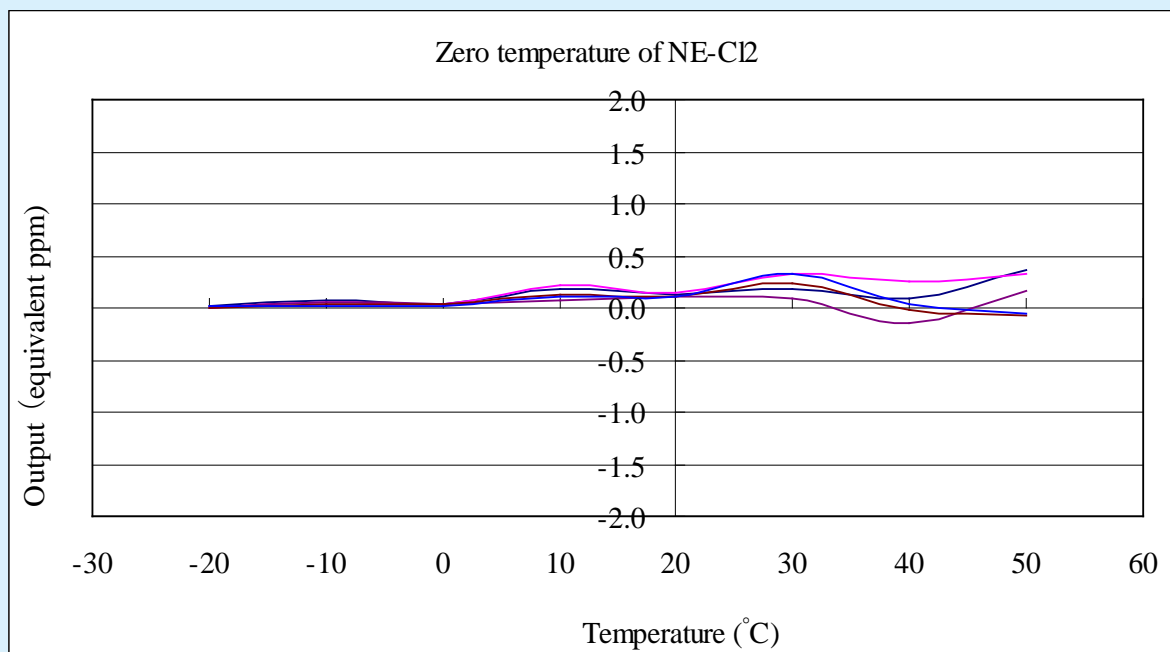

Fig. 3 : Typical temperature coefficient of NE4-CI2
(100 at 20 °C)



9-4. Temperature dependence

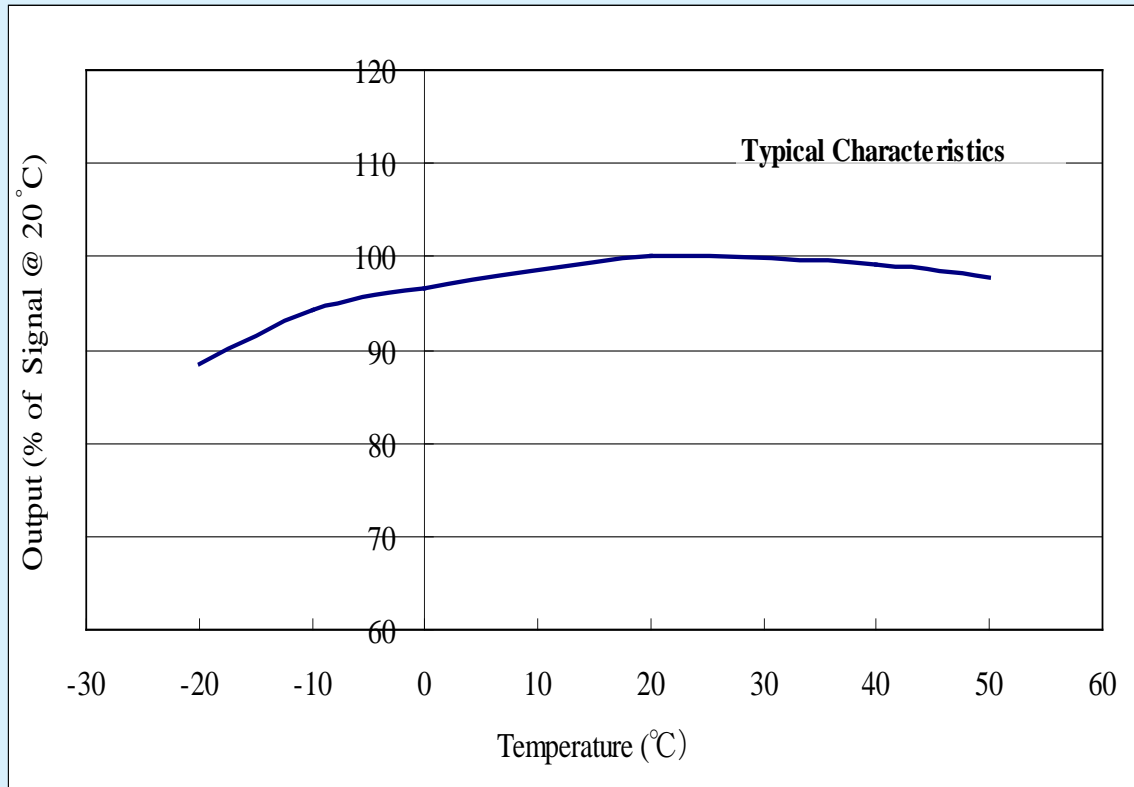

Fig. 4: Typical temperature coefficient of NE4-Cl2
(100 at 20 °C)

9-5. Response and recovery characteristics

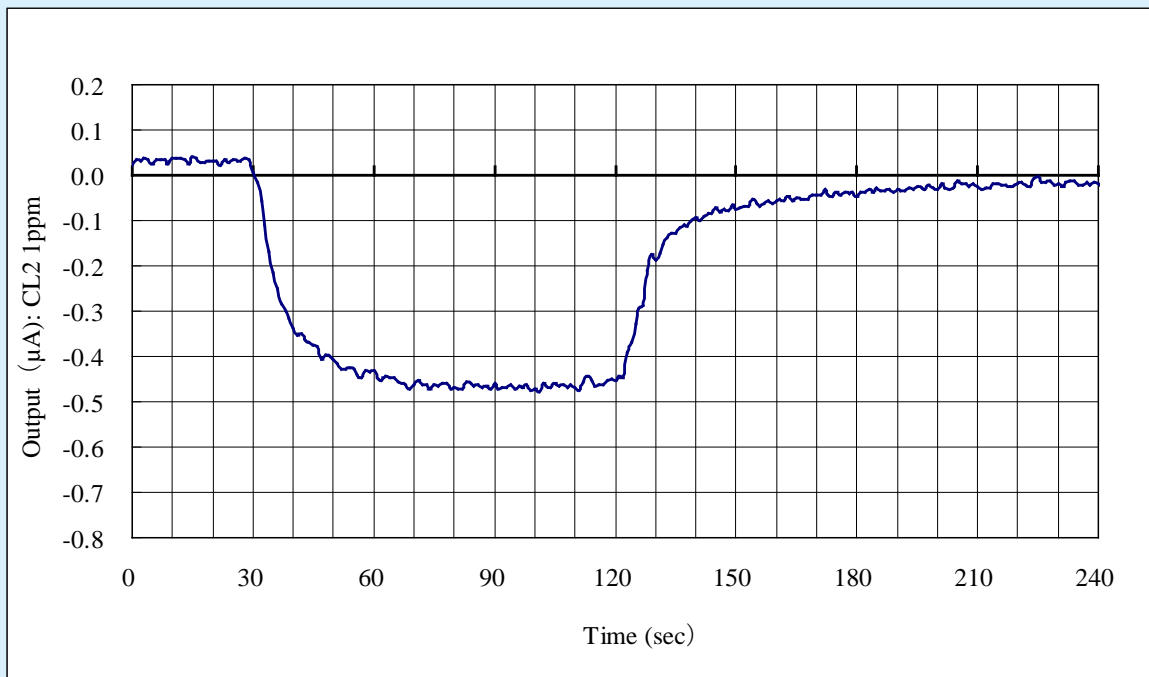

Fig.5: Response and recovery characteristics of NE4-Cl2
(at 20 °C)



9-5. Long term stability

It is quite stable in normal circumstance.

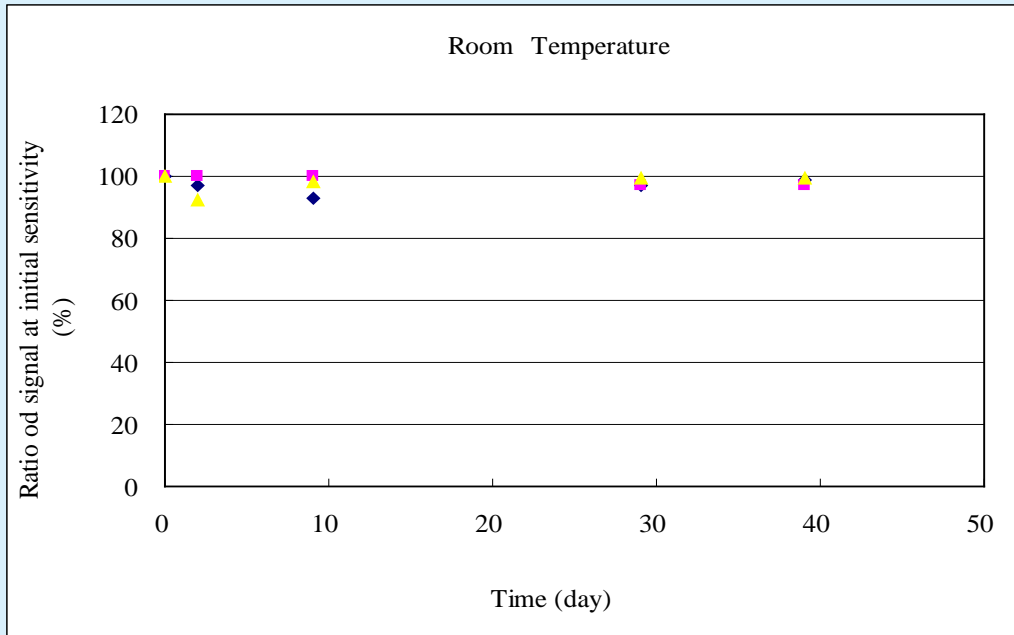

Fig.6: Long term stability in normal circumstance

10. Durability

NE4-C12 is much durable in strict environment such as high temperature and high humidity, or in high temperature with dry. Features are as follows.

10-1. High temperature durability

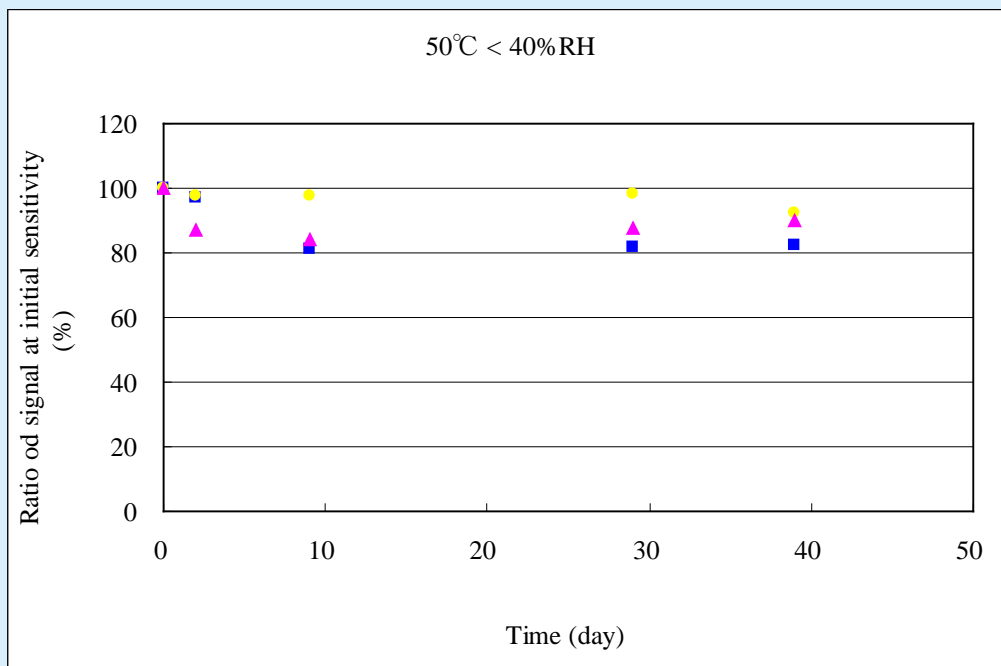

Fig.7: Durability in high temperature (50°C) with dry circumstance



10-2. Low temperature durability

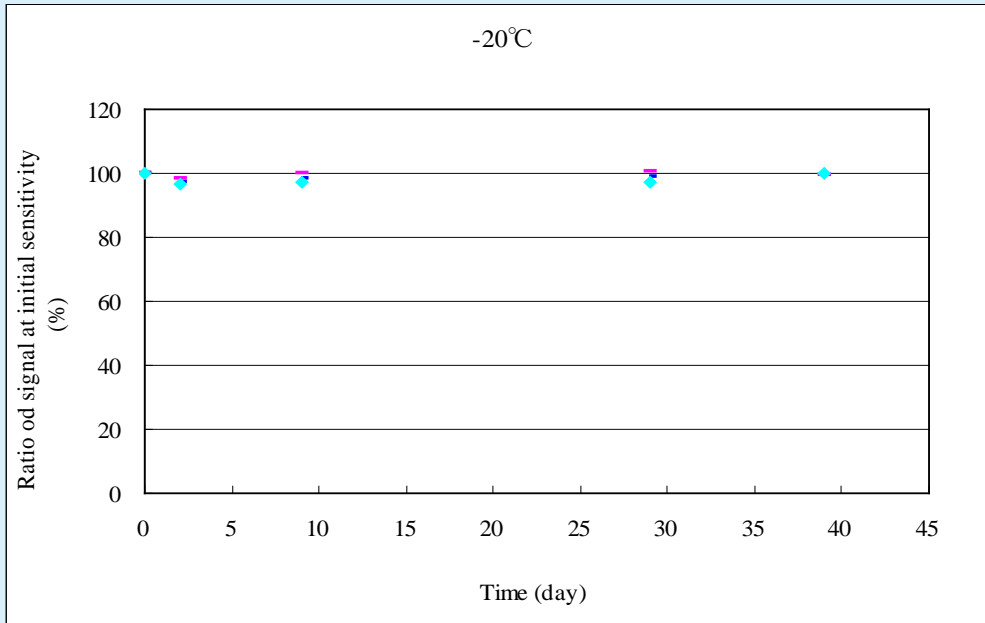

Fig.8: Durability in low temperature (-20°C)

10-3. Thermal shock test

Test conditions

Sensor is stored in -20 °C for 30min. and in +50 °C for 30 min. respectively, and this cycle were repeated for 10 times.

Table2. Thermal shock test

No.	Before test (micro A)		After test (micro A)		Sensitivity variation ratio (%)
	Zero offset in air at 20 degree C at 20 degree C	Sensitivity to 10ppm of Cl2	Zero offset in air at 20 degree C at 20 degree C	Sensitivity to 10ppm of Cl2	
1	0.08	-6.72	0.04	-6.68	99.4
2	-0.07	-6.79	0.05	-6.79	100.6
3	0.10	-5.88	0.10	-6.00	102.5
4	-0.07	-5.89	0.03	-5.89	101.9
5	-0.07	-6.05	0.05	-6.04	99.8



10-4. Drop test

Test conditions

Sensor is dropped to concrete floor from the height of 1m with free fall for 5 times.

Table3. Drop test

No.	Before test (micro A)		After test (micro A)		Sensitivity variation ratio (%)
	Zero offset in air at 20 degree C at 20 degree C	Sensitivity to 10ppm of Cl2	Zero offset in air at 20 degree C at 20 degree C	Sensitivity to 10ppm of Cl2	
1	-0.06	-6.34	-0.07	-6.43	101.4
2	-0.07	-6.45	-0.06	-6.76	104.8
3	-0.06	-5.93	-0.04	-6.00	101.2
4	-0.06	-6.65	-0.07	-6.84	102.8
5	-0.05	-6.02	-0.06	-6.01	99.8

11. Recommended circuit diagram

Recommended circuit diagram for evaluation of NE4-Cl2 is shown in figure 5. In this circuit diagram, OP97 as operational amplifier is employed, however the other low price one is to be applicable for actual use. And, thermistor is also employed, resistance value of 10Kohm at 25 °C and around 3500 as B constant is recommended. Ishizuka thermistor is not pointed, and another one is also available.

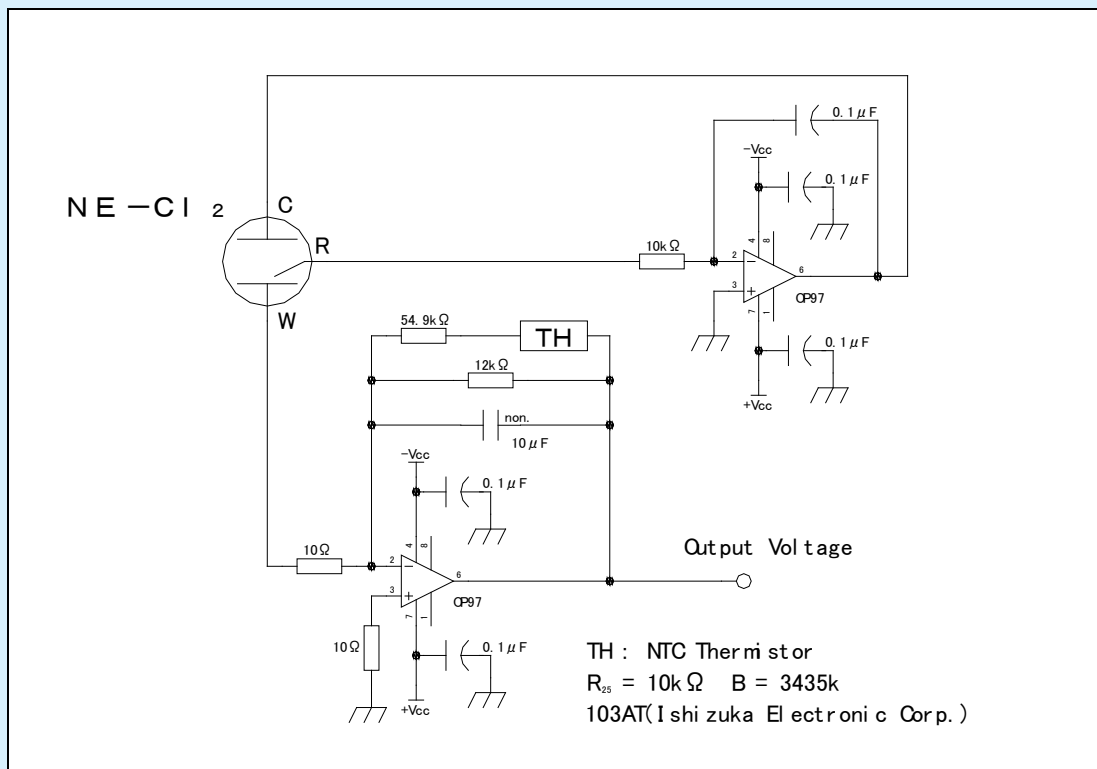

Fig. 5: Measuring circuit diagram for evaluation



12. Notices on handling

12-1. Seasonal variation of sensitivity

Highly hygroscopic electrolyte is normally employed for electrochemical sensor, and then the sensitivity varies according to change of temperature and humidity, i.e. sensitivity is little lower in low humidity than in high humidity. Since it is because of amount of electrolyte, this seasonal variation of sensitivity should be taken into account in case that precise measurement is necessary. However, this variation is reversible phenomenon.

12-2. Design of gas alarm or gas densitometer

- a. Calibration of gas alarm or gas densitometer is to be carried out in clean air after the output was stabilized.
- b. Gas sensitivity reduction ratio of 2% per month is to be taken into account at designing of gas alarm as recommendation. In case that precise detection is required, periodical calibration.
- c. In case that water drop or oil is on the pre-filter, accurate measurement may not be available because of low diffusion of detected gas to sensor. If such accident may be conceived, design of prevention from such one is to be considered.
- d. Warranty time is 2 years in case of being used in normal circumstance.

12-3. Storage of sensor

It is recommended that electrochemical sensor should be stored in normal temperature and humidity, possibly 0-20 °C, of clean air.

Recommended storage time after delivery is less than 6 months. If the storage time is extended, the warranty term is to be shortened. It is because the lifetime of electrochemical sensor is not dependent on being electrified or not like semi-conductive type or catalytic type, and then this matter is to be correctly comprehensive in order to keep quality.

12-4. General notice

- Use only within specified conditions.
- Sensor characteristics must be measured in clean air.
- Electrode pins must be correctly connected. Wrong connection does not allow correct functions.



- Do not apply voltage directly to electrode pins.
- Do not bend pins.
- Do not put excess vibration or shocks.
- If sensor housing is damaged or scratched, do not use.
- Do not blow organic solvents, paints, chemical agents, oils, or high concentration gases directly onto sensors.
- Do not solder pins of sensor directly. Use exclusive sockets.
- Do not disassemble or change any parts.
- Do not use contact grease when sensor is connected to the sockets.
- In case that sensor is stored by detachment from circuit board, it is recommended that working electrode pin should be short-circuited with reference electrode pin in order to shorten the initial stabilization time.
- If sensor is used under irregular atmosphere, contact us.

Nemoto Sensor Engineering Co., Ltd.
4-10-9 Takaido-Higashi Suginami-ku Tokyo 168-0072 Japan
TEL 81-03-3333-2760 FAX 81-03-3333-7344

Tech.Inf.No.NE4-C12-120918