

Rotierender Drehmomentsensor (Schleifring)**Typ DR-12****rotation torque sensor (slipring)**

- Mit integrierter Drehwinkelmessung
- Mit Innen- und Außenvierkant
- integrated angle control
- both side with square end



Messbereich <i>nominal torque</i> [Nm]	Vier- kant <i>square</i>	Nenn- kennwert <i>sensitivity</i> [mV/V]	max. Dauer- drehzahl <i>cont. max speed</i> [min ⁻¹]	Feder- konstante <i>spring rate</i> [Nm/rad]	max Querlast [N] <i>max lateral load</i>	Massen- trägheitsmoment <i>moment of inertia</i> J in [kg m ²] Antriebsseite <i>drive side</i>	Gewicht <i>weight</i> [kg]
1	1/4"	0,5	2000	1,4·10 ²	4	3,2·10 ⁻⁶	0,5
2	1/4"	0,5	2000	4,5·10 ²	5	3,3·10 ⁻⁶	0,5
5	1/4"	2	2000	3,0·10 ²	7	3,2·10 ⁻⁶	0,5
12	1/4"	2	2000	6,7·10 ²	7,5	3,3·10 ⁻⁶	0,5
25	3/8"	2	1500	2,4·10 ³	12	1,2·10 ⁻⁵	0,5
63	3/8"	2	1500	6,8·10 ³	28	1,2·10 ⁻⁵	0,5
160	1/2"	2	1500	1,2·10 ⁴	65	1,7·10 ⁻⁵	0,6
500	3/4"	2	1000	3,9·10 ⁴	200	9,2·10 ⁻⁵	1,3
1000	1"	2	1000	8,9·10 ⁴	240	3,6·10 ⁻⁴	1,5
2000	1 1/2"	2	500	3,6·10 ⁵	450	3,3·10 ⁻³	7,9
5000	1 1/2"	2	500	4,4·10 ⁵	500	3,4·10 ⁻³	8



Eine kurzzeitige Überschreitung der Maximaldrehzahl um Faktor 1,5 ist möglich

Grenzspezifikation: $t_{max} \leq 1 \text{ min}$ bei 50% ED

A short time overstep of the maximum speed is possible by a factor 1,5

worst case: $t_{max} \leq 1 \text{ min}$ at 50% on period.

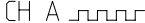
TECHNISCHE DATEN - specifications

TYP - type		DR-12
Genauigkeitsklasse - <i>accuracy class</i>	% v.E	0,1
Kennwerttoleranz - <i>tolerance of sensitivity</i>	%	±0,1
Reproduzierbarkeit n. DIN 1319 - <i>nonrepeatability</i>	%	±0,05
Speisespannung - <i>excitation voltage</i>	V	2 ... 12
max Speisespannung - <i>max excitation voltage</i>	V	15
Speisespannung Winkel - <i>excitation voltage angle</i>	v	5
Impulse / Umdrehung - <i>Imp. / Rotation</i>		360
Spuren 90° versetzt - <i>channel 90° (quadrature)</i>		2
Pegel - <i>Signal</i>	V	5 (TTL)
Rechtsdrehung - CW - turn		
CH A  CH B 		
Brückenwiderstand - <i>bridge resistance</i>	Ω	350
Nenntemp.bereich - <i>nominal temp. range</i>	°C	+5 ... +50
Gebrauchstemp.bereich - <i>service temp. range</i>	°C	-10 ... +60
Verdrillwinkel bei Nennmoment - <i>twist angle by nominal load</i>	°	<0,5
Grenzmoment (statisch) - <i>limit torque</i>	% v.E.	130
Gebrauchsmoment - <i>service torque</i>	% v.E.	120
Bruchmoment (statisch) - <i>ultimate torque</i>	% v.E.	250
Standzeit der Bürsten ca. - <i>durability of brushes</i>	Umdr.-rev.	5x10 ⁷
Schwingbreite (DIN 50100) - <i>bandwidth</i>	%	70 (Spitze - Spitze) - (top - top)
Schutzart - <i>level of protection</i> (DIN EN 60529)	IP 50	
Anschlußstecker - <i>connector</i>	12 polig 12-pin	

Anschlussbelegung - connection

12-polig 12-pin		
Pin A	Vers. (GND) DMS - <i>excitation strain gauge</i>	0V
Pin B	Vers. (+) DMS - <i>excitation strain gauge</i>	2...12 V
Pin C	Sign. (+) - <i>signal</i>	
Pin D	Sign. (-) - <i>signal</i>	
Pin E	Vers. Winkel - <i>excitation angle</i>	0V
Pin F	Vers. Winkel - <i>excitation angle</i>	+5V
Pin G	Winkel A (TTL) - <i>angle A (TTL)</i>	
Pin H	Winkel B (TTL) - <i>angle B (TTL)</i>	
Pin J	Winkel - <i>angle</i>	0V
Pin K	Kontrolle - <i>calibration control</i>	(Option - option)
Pin L	NC	
Pin M	Schirm - <i>shield</i>	

Mechanische Abmessungen – dimensions

DR-12

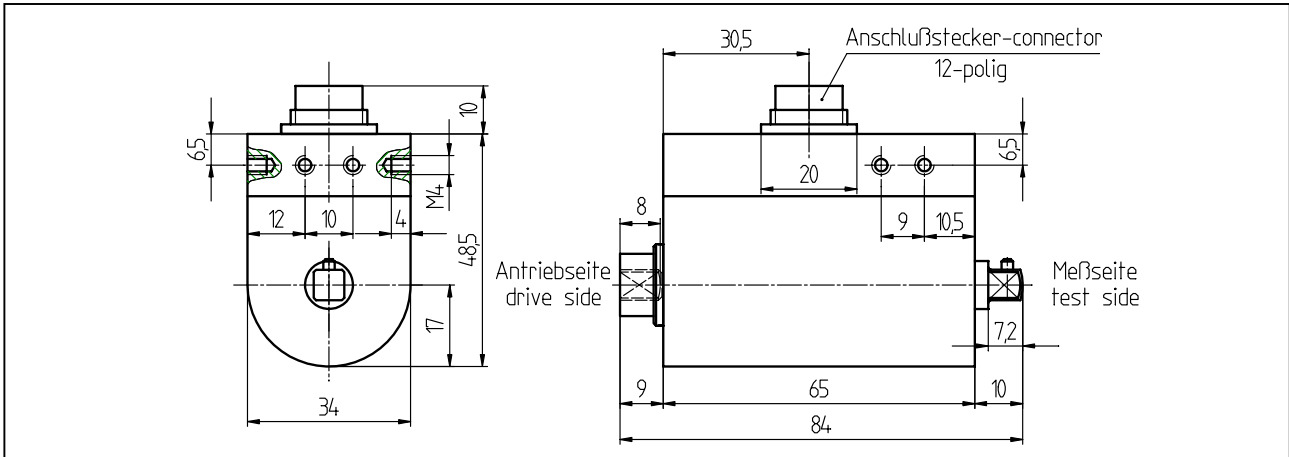

Messbereich - nominal torque [Nm]	Vierkant - square
0...12	1/4"

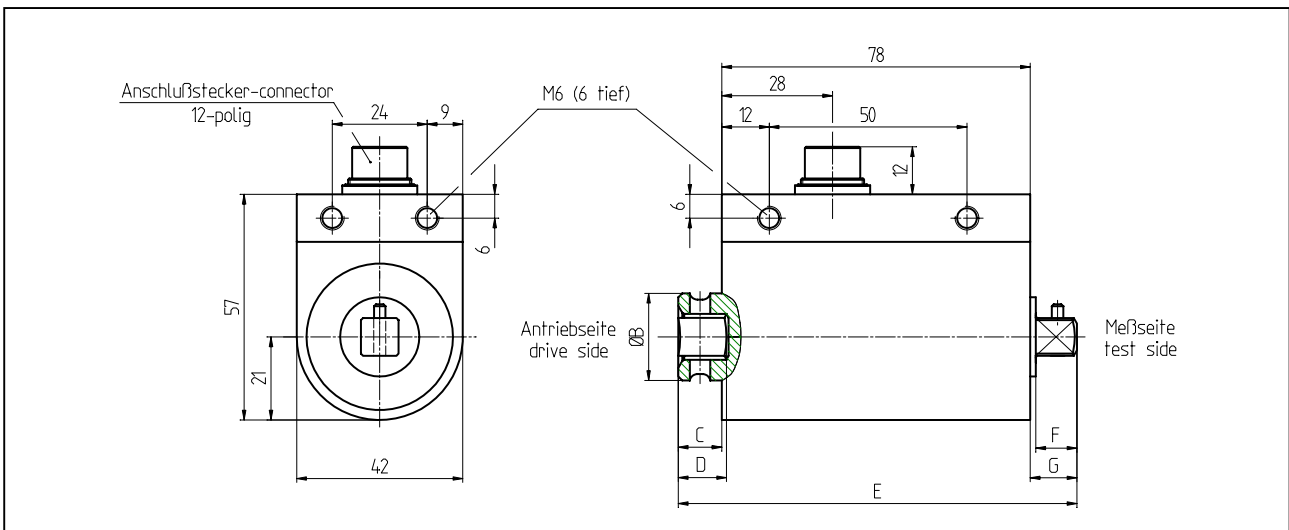

Messbereich nominal torque [Nm]	Vierkant square	Abmessungen - dimensions [mm]					
		B	C	D	E	F	G
0...63	3/8"	22	11	12,2	100,8	10,4	11,8
0...160	1/2"	29,8	12	16,9	106	15,1	16

Mechanische Abmessungen – dimensions

DR-12

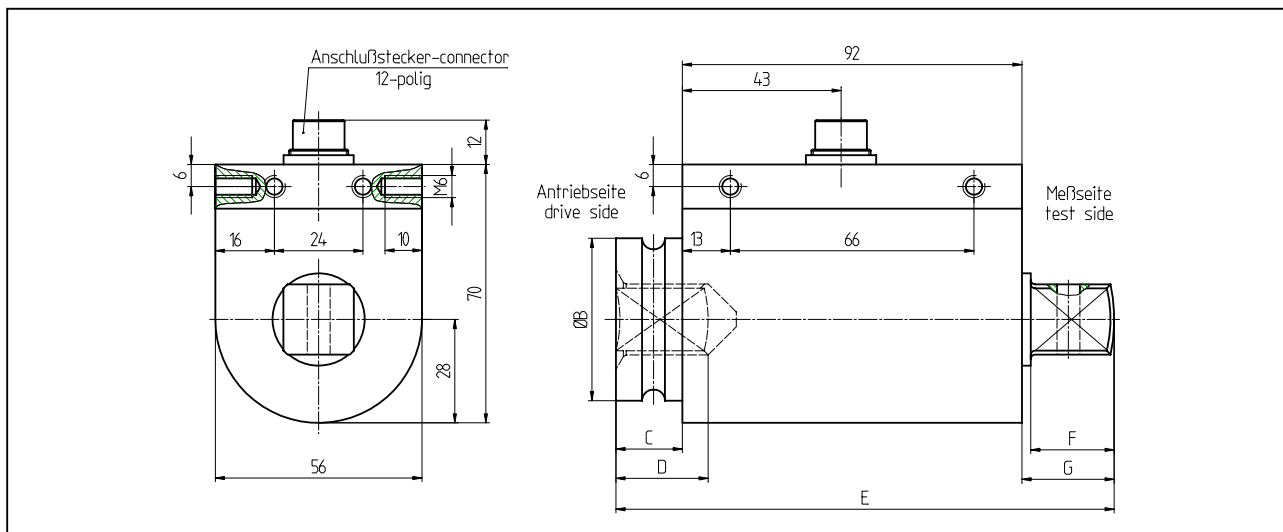

		Abmessungen - dimensions [mm]					
Messbereich nominal torque [Nm]	Vierkant square	B	C	D	E	F	G
0...500	3/4"	44	18	24,9	135	22,6	25
0...1000	1"	54	53,1	29,9	177	27,3	31,9

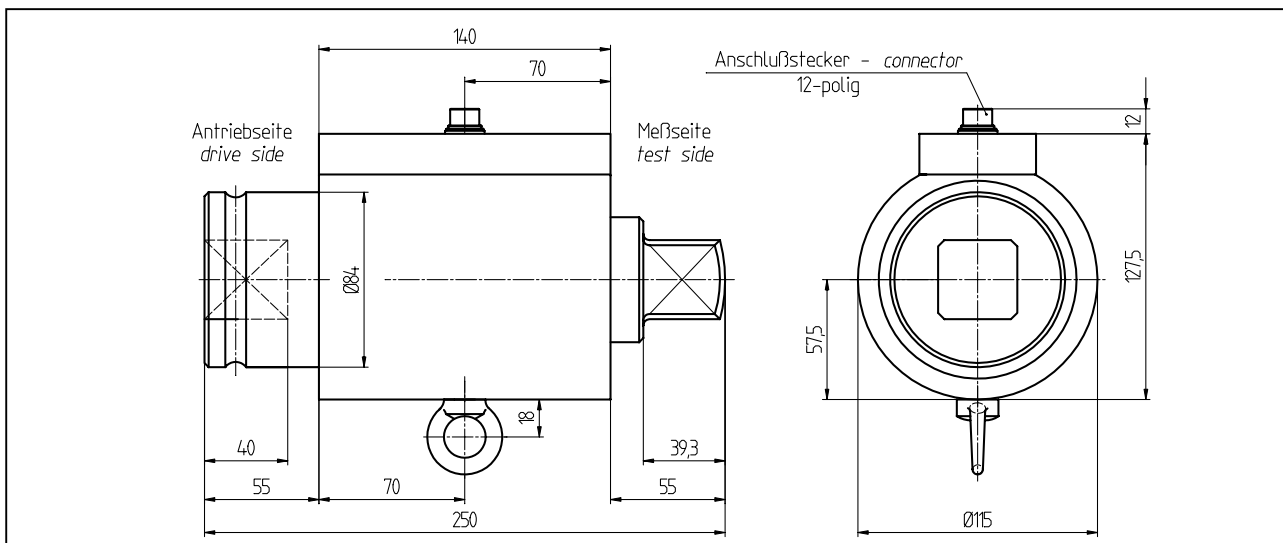

Messbereich - nominal torque [Nm]	Vierkant - square
0...5000	1 1/2"